



## CFD ANALYSES OF A TWO-STAGE NATURAL GAS PRESSURE REGULATOR

Mutlu TEKİR<sup>1\*</sup>, Engin GEDİK<sup>2</sup>, Erol ARCAKLIOĞLU<sup>1</sup>, Murat ÇALAPKULU<sup>3</sup>, Mehmet Cem KASAP<sup>3</sup>

<sup>1</sup>Department of Mechanical Engineering, Faculty of Engineering, Karabük University  
mutlutekir@karabuk.edu.tr, arcakli@karabuk.edu.tr

<sup>2</sup>Department of Energy Systems Engineering, Faculty of Technology, Karabük University  
egedik@karabuk.edu.tr

<sup>3</sup>Eska Valve, Ltd. İstanbul  
mcalapkulu@eskavalve.com, ckasap@eskavalve.com

Received: 27.10.2015, Accepted: 26.02.2016

\* Corresponding author

### Abstract

Pressure regulators are mechanical devices that control the motion of the machines or flow of fluids to meet specific standards. Service pressure regulators, that provide the pressure range in which end-user can use natural gas, have the capability of shut-off gas in unexpected conditions without endangering operating medium. Service pressure regulators reduce 4-6 bar upstream pressure to generally 21 mbar downstream pressure. In this study a two-stage pressure regulator has been designed, and flow characteristics of the regulator have been analyzed numerically by Ansys Fluent that runs based on finite volume technique. According to the results obtained from numerical study, optimum rate of orifice gaps of each stage in the regulator has been determined, and taking account of basic flow characteristics like parameters of pressure drop, velocity scatter, etc., results are presented in graphics and discussed in detail.

**Keywords:** Natural Gas, Regulator, Computational Fluid Dynamics

## ÇİFT KADEMELİ DOĞALGAZ BASINÇ REGÜLATÖRÜNÜN HESAPLAMALI AKIŞKANLAR DİNAMİĞİ İLE SAYISAL ANALİZİ

### Özet

Basınç düşürücü belirli bir standardı karşılamak amacıyla makinelerin hareketini ya da sıvı veya gazların akışını kontrol eden mekanik cihazlardır. Doğalgaz dağıtım hatlarından verilen gazın son kullanıcının kullanabileceği basınç aralığına getiren ve beklenmeyen bir durumda gaz kullanım sistemlerine ve çevreye zarar vermeden gazı kesebilen servis basınç düşürücüler 4-6 bar arasında gelen doğal gaz basıncını genellikle 21 mbar çıkış basıncına düşürürler. Yapılan bu çalışmada çift kademeli olarak basınç düşürme işlemini gerçekleştiren bir doğalgaz basınç düşürücü tasarlanarak, basınç düşürücü içerisindeki akış karakteristikleri sonlu hacimler tekniğine dayalı çözüm yapan Ansys Fluent programında sayısal olarak incelenmiştir. Sayısal çalışmadan elde edilen sonuçlara göre basınç düşürücü içerisindeki kademelerin optimum açıklık oranları belirlenmiş ve temel akış karakteristikleri olan basınç düşümü, hız dağılımı gibi parametreler dikkate alınarak sonuçlar grafikler halinde sunulmuş ve detaylı bir şekilde tartışılmıştır.

**Anahtar Kelimeler:** Doğalgaz basınç düşürücü, basınç regülatörü, hesaplamalı akışkanlar dinamiği (HAD)

### 1 Introduction

Pressure regulators are defined as mechanisms that control or manage the flow of fluids or movements of machines in order to meet a specific standard. Primary function of pressure regulators is to meet the requirements of fluid pressure and flow. To meet this requirements, it makes necessary adjustments while measuring the outlet pressure [1-2].

Natural gas pressure regulators are vital important in the role of transportation of natural gas to the consumer. Natural gas, that is delivered by pipelines with 80 bar pressure or by ships as liquefied (LNG), are regulated many times by pressure regulators until it reaches to the consumer. Natural gas transferred by 80 bar pressure is reduced to 4-6 bar by farm tap regulators, and then it is distributed to houses. To distribute natural gas to the flats, its pressure is reduced to 21-300 mbar by service pressure regulators, and it is brought into use of consumers [1].

Fundamental design of pressure regulators is very simple. It works with a flexible diaphragm of that outlet pressure is exposed on one side and pressure of loading element is exposed on the other side, and closing element connected to this diaphragm.

### 2 Methodology

Medium pressure  $P_2$  directly or indirectly affects the diaphragm of actuator mechanism of pressure regulators.  $F_K$  force that is resultant of pressure differential on the seat valve  $S$  and spring force  $F_F$  withstand  $F_M$  force that is resultant of diaphragm area  $A_M$  and medium pressure  $P_2$ .  $F_K$  occurs from inlet and outlet pressure differential of pressure regulator affecting on surface area of closing element. Spring withstands with increasing force in proportion to compression length according to its original length, thus preloading allows adjustment of operating pressure [1,3].

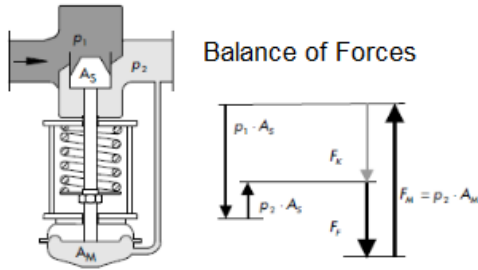

Figure 1. Balance of forces in a pressure regulator [1]

$A_s$  as valve seat area of closing element, and  $c_F$  as spring coefficient;

$$F_K = \Delta P \cdot A_S \quad (1)$$

$$F_F = c_F \cdot x \quad (2)$$

$$F_M = P_2 \cdot A_M = F_K + F_F \quad (3)$$

As seen in state of equilibrium in Figure 1, merest change of pressures causes change of balance, consequently closing element moves, and changes its position until new balance of forces is reached.

Inside of the complicated 3D model (Figure 2) of two-stage pressure regulator of that Eska Valve has developed preliminary design phase has been extracted to obtain flow domain (Figure 3). Three dimensional analyses have to be performed because 2D cross-section of model is not symmetrical and flow inside the regulator is complex. Furthermore it is obtained that changes in 3<sup>rd</sup> dimension affect results [1].

Results has been tried to be reached by changing gaps of 1<sup>st</sup> and 2<sup>nd</sup> orifices, because dynamic mesh and FSI couldn't be performed due to complexity of geometry. Gaps of 1<sup>st</sup> and 2<sup>nd</sup> orifices can be seen on Figure 4. During this study problems originating from geometry has been encountered, and some simplifications has been made on geometry. In this simplification process pressure balancing volumes, that are used for adjusting the gaps of 1<sup>st</sup> and 2<sup>nd</sup> orifices while measuring pressure via sensing line of pressure regulator, have been removed. This pressure balancing volumes haven't been needed because dynamic mesh or FSI couldn't be performed due to complexity of geometry [1].

After geometry is created, second step is to create mesh. Mesh creation is one of the most important steps that affects the accuracy of analysis. Ansys v15 has been used for analyses. Automated method in workbench was used while creating mesh, but also some refinements have been made on mesh. Surface sizing has been set low, multilayered cells have been used around boundary layers, and inflation layers have been used around sharp edges and the regions that flow could speed up; so higher accuracy of results has been aimed (Figure 5). At this point especially around 1<sup>st</sup> and 2<sup>nd</sup> orifices intense mesh cells have been created (Figure 5) [1].

After creating mesh, to start analysis necessary selections must be made in Fluent. Analyzed geometry has 6-60 m<sup>3</sup>/hour flow capacity. Let's discuss about calculations for 6 m<sup>3</sup>/hour flow capacity. Outlet velocity is 4.8 m/s then. Reynolds number, which is calculated by products of density, velocity and outlet diameter divided by dynamic viscosity, is used to define the characteristics of flow. As a result of these calculations, Reynolds number is found 6918 for 6 m<sup>3</sup>/hour flow capacity. In this situation for most of the flow capacities flow is turbulent. Taken into account advantages and disadvantages of all turbulence models, that flow being fully developed turbulent

flow, complex geometry and computational time; it has been decided that k-ε turbulence model would be convenient and have been used mostly. On the other hand also standard k-ω and SST k-ω were used on the purpose of comparing.

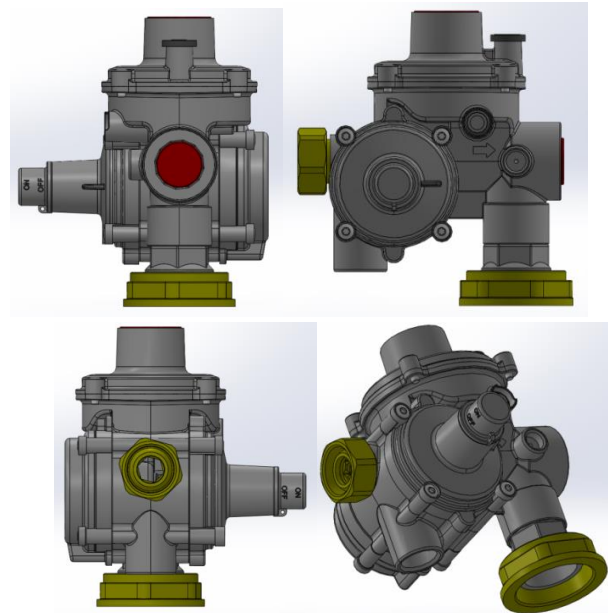

Figure 2. Views of two-stage natural gas pressure regulator [1]

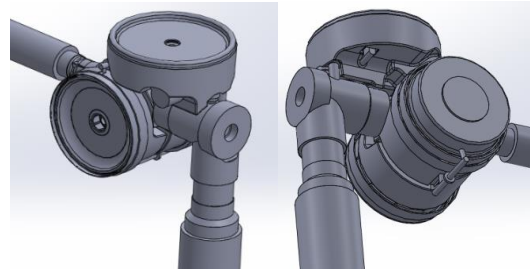

Figure 3. Flow domain extracted from 3D model [1]

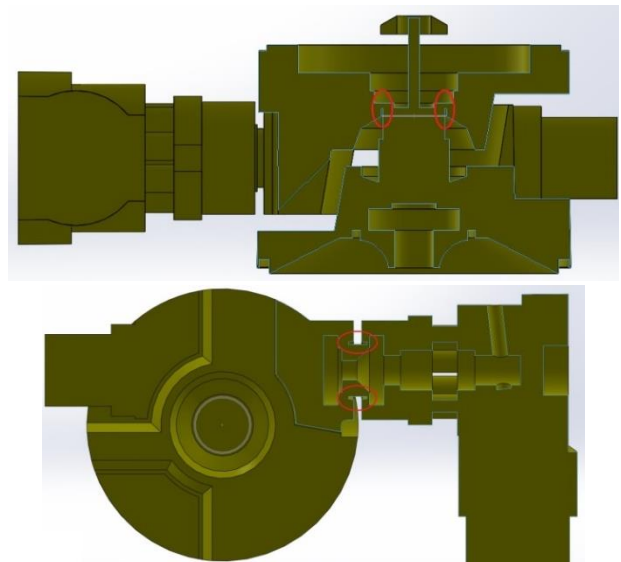

Figure 4. 1<sup>st</sup> and 2<sup>nd</sup> orifices from cross-section views of regulator [1]

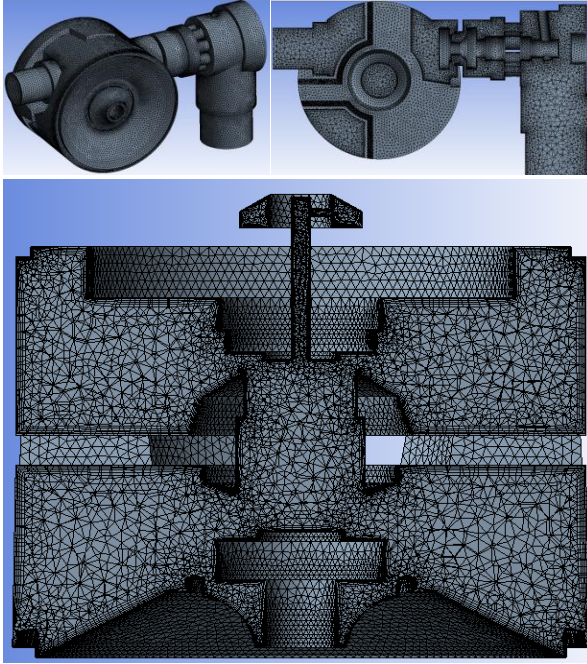

Figure 5. Views of mesh performed on 3D model and cross-section of orifices [1]

Furthermore, turbulence models play important role in these analyses that flow is included. As mostly k-ε turbulence model had been used, turbulent kinetic energy k and its dissipation rate ε are calculated from the transport equations below.

$$\frac{\partial}{\partial t}(\rho k) + \frac{\partial}{\partial x_i}(\rho k u_i) = \frac{\partial}{\partial x_j} \left[ \left( \mu + \frac{\mu_t}{\sigma_k} \right) \frac{\partial k}{\partial x_j} \right] + G_k + G_b - \rho \varepsilon - Y_M + S_k \quad (4)$$

$$\frac{\partial}{\partial t}(\rho \varepsilon) + \frac{\partial}{\partial x_i}(\rho \varepsilon u_i) = \frac{\partial}{\partial x_j} \left[ \left( \mu + \frac{\mu_t}{\sigma_\varepsilon} \right) \frac{\partial \varepsilon}{\partial x_j} \right] + C_{1\varepsilon} \frac{\varepsilon}{k} (G_k + C_{3\varepsilon} G_b) - C_{2\varepsilon} \rho \frac{\varepsilon^2}{k} + S_\varepsilon \quad (5)$$

Eddy viscosity is calculated from the equation below.

$$\mu_t = \rho C_\mu \frac{k^2}{\varepsilon} \quad (6)$$

$$C_{1\varepsilon}=1.44, C_{2\varepsilon}=1.92, C_\mu=0.09, \sigma_k=1.0, \sigma_\varepsilon=1.3 \quad (7)$$

$G_k$  is the generation of turbulent kinetic energy due to mean velocity gradients,  $G_b$  is the generation of turbulent kinetic energy due to buoyancy,  $Y_M$  is the contribution of the fluctuating dilatation in compressible turbulence to the overall dissipation rate,  $C_{1\varepsilon}$ ,  $C_{2\varepsilon}$ ,  $C_{3\varepsilon}$  are constants,  $\sigma_k$  and  $\sigma_\varepsilon$  are the turbulent Prandtl numbers for k and ε,  $S_k$  and  $S_\varepsilon$  are user-defined source terms.

Another factor that affects the accuracy of results is accuracy and choice of boundary conditions. In this study inlet area was defined as pressure inlet, and its pressure was set 400 000 Pa. Outlet area was defined as pressure outlet, and its pressure was set 0 Pa in order to find outlet pressure and velocity automatically [1].

To finalize iteration process, residuals had to be at least e-06 order, and also velocity, pressure changes had been observed. If the changes of these parameters were going on, iterations had continued.

### 3 Analyses Results

Another factor that affects accuracy of results is quality and cell number of mesh. Poor quality mesh or smaller mesh number causes to decrease accuracy of results, while higher mesh number increases computational time. Therefore mesh study is very crucial to reach reasonable accuracy of results within reasonable computational time.

Table 1. Analyses data from mesh study [1]

Analysis 1st Orifice (mm) 2nd Orifice (mm) Turbulence Model	Mesh Number	Minimum Cell Size	Outlet Pressure (Pa)	Outlet Velocity (m/s)	y+	Mesh Orthogonal Quality
1	7 277 679	0.0010	2013	56.56	-	-
2	5 593 822	0.0050	2007	56.40	10.67	0.866
3	5 112 214	0.0194	2031	56.80	10.82	0.865
4	3 511 285	0.0774	1984	56.10	13.91	0.861
5	3 056 670	0.1000	2073	57.40	16.53	0.857
6	1 344 551	0.5000	2082	57.46	17.17	0.852

Graphics obtained from data in Table 1 are as follows.

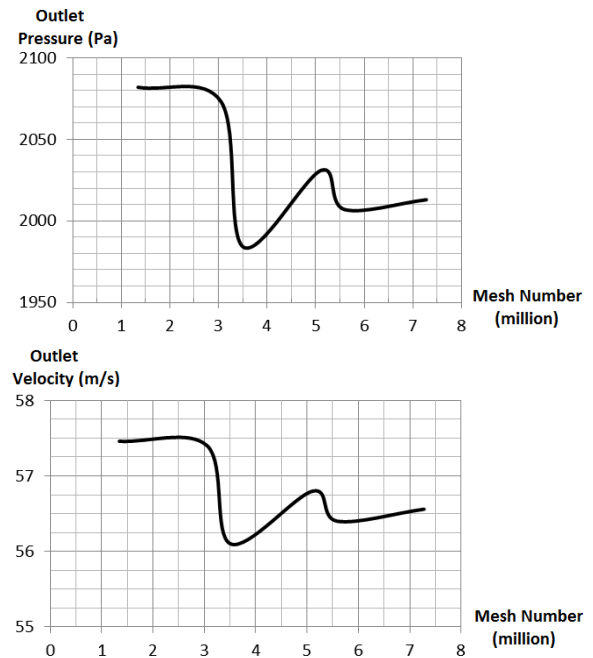

Figure 6. Change of outlet pressure according to mesh number (at top), and change of outlet velocity according to mesh number (at bottom) [1]

In mesh study of this study gaps of orifices of two-stage pressure regulator were set to maximum. Geometry whose 1st orifice was set 2.0 mm, and 2nd orifice was set 3.0 mm has been analyzed, and results can be seen in Table 1, Figure 6, and 7.

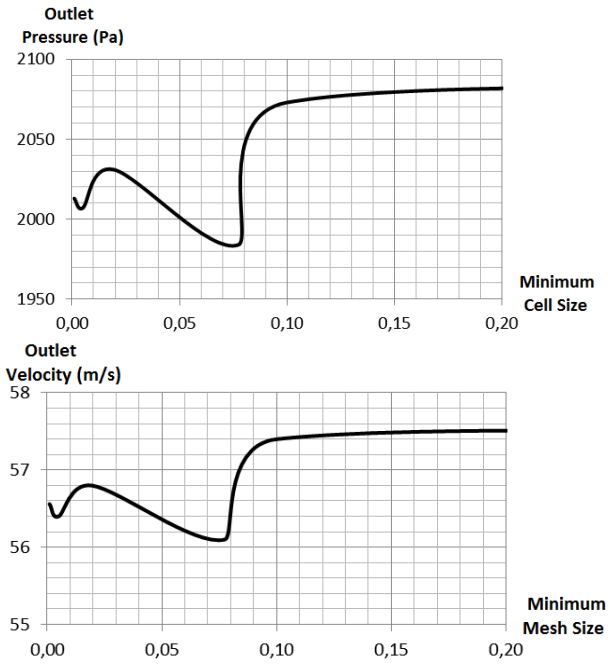

Figure 7. Change of outlet pressure according to minimum cell size (at top), and change of outlet velocity according to minimum cell size (at bottom) [1]

As seen in the graphics, while mesh number increases and minimum cell size decreases, outlet pressure and velocity converge. After a certain value, error rate decreases, but increasing mesh number and decreasing minimum cell size can significantly increase computational time. Therefore Analysis 3 with 0.0194 minimum cell size and 5 112 214 mesh number has been used as a base for other analyses that are going to be performed.

Subsequent to mesh study various analyses have been performed using different gaps of orifices, different turbulence models and calculation methods. After constant density conditions, ideal gas and real gas conditions were simulated. Constant density and k- $\epsilon$  standard wall function turbulence model have offered the best results amongst, but it has been seen that decreasing orifice gap increases error rate. As an analysis of preliminary design, these results have validated the wanted pressure and flow capacity values of the pressure regulator.

Best results reached can be seen in Table 2, and pressure, flow capacity curve according to gap of 2<sup>nd</sup> orifice based on these analyses results can be examined in Figure 8. The best result has been achieved when gaps of each orifices were set to maximum, in other words 1<sup>st</sup> orifice gap was 2 mm and 2<sup>nd</sup> orifice gap was 3 mm.  $y^+$  surface contours, pressure, and velocity contours, and streamlines of these analyses are given below.

Table 2. List of most accurate results [1]

Analysis	1 <sup>st</sup> Orifice (mm)	2 <sup>nd</sup> Orifice (mm)	Turbulence Model	Mesh Cell	Outlet Pressure (mbar)	Outlet Velocity (m/s)	Flow Capacity (m <sup>3</sup> /h)	$y^+$	Orthogonal Quality	Turbulence Intensity (%)	Vorticity
1	2.0	0.5	Std. K-E Std. Wall Fnc	5 471 101	4.39	26.5	32.98	6.33	0.865	98	31260
2	2.0	1.0	Std. K-E Std. Wall Fnc	5 454 407	11.06	42.0	52.37	8.66	0.865	149	41150
3	2.0	1.5	Std. K-E Std. Wall Fnc	5 585 029	16.78	51.6	64.34	10.16	0.865	180	47581
4	2.0	2.0	Std. K-E Std. Wall Fnc	5 178 111	20.35	57.0	71.07	10.74	0.865	190	48558
5	2.0	2.5	Std. K-E Std. Wall Fnc	5 486 237	19.55	55.7	69.45	10.58	0.865	189	47060
6	2.0	3.0	Std. K-E Std. Wall Fnc	5 112 214	20.49	56.0	69.83	10.78	0.865	2610	45749

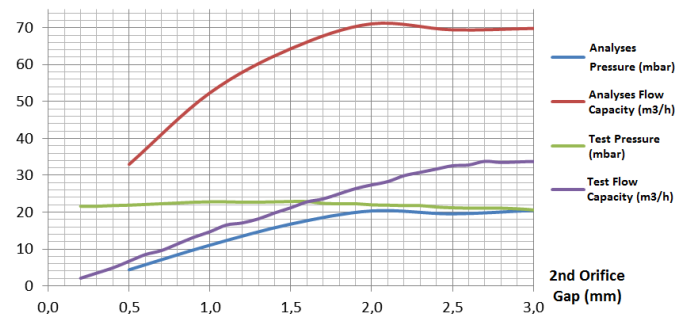

Figure 8. Change of pressure and flow capacity according to gap of 2<sup>nd</sup> orifice. [1]

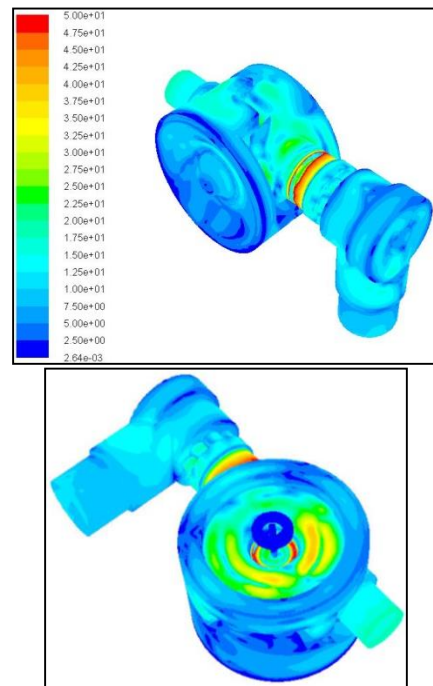

Figure 9. Wall  $y^+$  surface contours of natural gas pressure regulator from two different angles [1]

As seen in Figure 9 wall  $y^+$  values are generally under 15, on some regions this value increases, but surface average is under 10, so this shows that mesh is good quality.



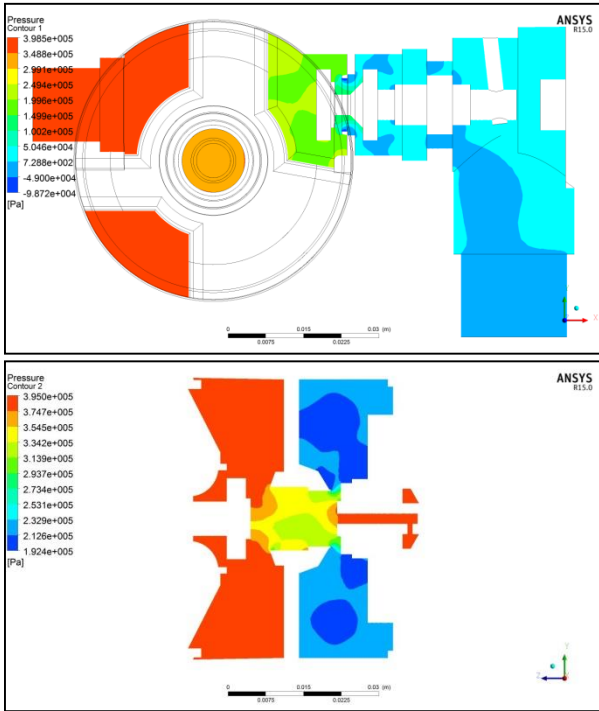

Figure 10. Pressure contour of XY cross-section (at top) and pressure contour of YZ cross-section (at bottom) [1]

As seen in Figure 10, pressure contours from both XY and YZ cross-sections shows that pressure drops between 1-2 bar at 1st orifice. Also, outlet pressure gives the wanted value.

to turbulent flow in outlet pipe, velocity contour on outlet surface is formed as Figure 12.

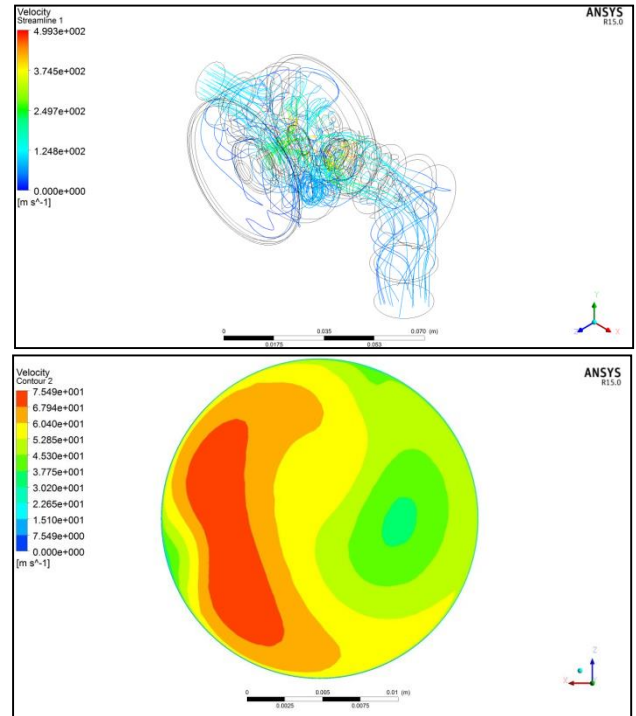

Figure 12. Velocity streamlines through the regulator (at left) and velocity contour of outlet surface (at right) [1]

#### 4 Conclusion and Further Work

Computational fluid dynamics analyses are theoretical studies that are performed to remove uncertainty before tests, and to simulate real conditions in an effort to reduce test numbers. There are situations that these analyses can give faulty results, because these are theoretical studies. Reasons of these faulty results are numerical errors, coding errors, and user errors. Rounding errors, iterative converging errors, and discretization errors can be given in example to numerical errors. Coding errors are mistakes that are natural in unverified CFD codes, softwares. Lastly user errors point out human faults that are resulted by incorrect use of software. Besides also user errors like both incorrect selection of solver methods, turbulence models, and constrain of computational time, incorrect mesh creation cause faulty results. For this reason in this study mesh number that provides good accuracy according to computational time was taken as a base, as a result of mesh study; likewise double precision in solver settings have been selected.

Analyses in which geometries with small gaps of orifices were performed have resulted not as it was expected. Reasons for this are that orifices gaps couldn't be adjusted sensitively, increasing residuals originating from complex geometry throughout iterative calculations of flow equations could affect results, or turbulence equation could have difficulty in simulating turbulent flow around each orifices of pressure regulator. It is determined that small and large angles of butterfly valve cause deviation of results [4]. It is thought that turbulence model has difficulty in trying to simulate real turbulent behavior via RANS equation for small angles because the flow is restricted around butterfly valve. Besides for large angles high amount of turbulence occurs, so it is thought that

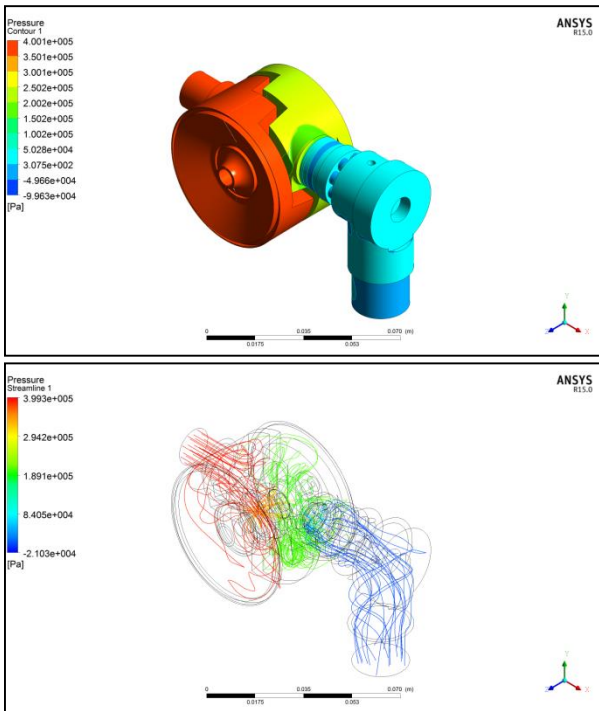

Figure 11. Surface pressure contours (at top) and pressure streamlines through the regulator (at bottom) [1]

Pressure and velocity values on the streamlines of Figure 11 and 12 can be seen. 4 bar inlet pressure drops by degrees, and flow velocity increases while flow passes through orifices. Due

this affects results [4]. At the same time small angle gaps result greater errors in other studies that Song et al. [5] investigated on butterfly valve and Chaiworapuek et al. [6] researched in another. This study and these other studies are quite similar.

It can be seen that flow capacity is 60-70 m<sup>3</sup>/h in analyses that right pressure values achieved in. It is because pressure regulator body whose capacity is 25 m<sup>3</sup>/h going to be used for regulators whose capacity is 60 m<sup>3</sup>/h. Regulator body has been designed for 10-60 m<sup>3</sup>/h flow capacities, and different capacities are achieved by adjusting spring preloading of each orifices. At small gaps of each orifices CFD software had difficulty in guessing the results right, at large gaps accurate results had been reached. Also some improvements can be contributed during product development process by analyzing other parts, or mechanical and nodal analyses.

## 5 References

[1] Tekir, M., "ift Kademeli Dođalgaz Basın Reglatrnn Hesaplamalı Akıřkanlar Dinamiđi ile Sayısal Analizi", Yksek Lisans Tezi, Karabk niversitesi, Karabk, 1-102 (2015).

[2] Lightfoot, D., "Fundamentals of Pressure Regulators", American Meter Company (2009).

[3] Samson AG, "Introduction to Self-Operated Regulators, L202 EN", Mess-Und Regeltechnik (07/2000).

[4] Del Toro, A., "Computational fluid dynamics analysis of butterfly valve performance factors", Master's Thesis, Utah State University, Logan, USA, 1-134 (2012).

[5] Song, X, Wang, L, and Park, Y., "Fluid and structural analysis of large butterfly valve", AIP Conference Proceedings, 1052: 311-314 (2008).

[6] Chaiworapuek, W., Champagne, J., El Haj em, M., and Kittichaikan, C., "An nvestigation of the water flow past the butterfly valve", AIP Conference Proceedings, 1225: 249-262 (2010).

[7] Skousen, P., "Valve handbook", NY: McGraw Hill, New York (2007).

[8] Mane, P., Computational Study of Poppet Valves on Flow Fields, MSc. Thesis, Youngstown State University. (Dec, 2013)

[9] Domagala, M., "CFD Analyses Of Pilot Operated Relief Valve", Czasopismo Techniczne (03/05/2008).