

# Description and Development of a Measuring System for the PEM Fuel Cell Polarization Curve

Arafet Bouaicha<sup>1</sup>, Hatem Allagui<sup>2</sup>, El-Hassane Aglzim<sup>3</sup>, Amar Rouane<sup>4</sup>, Abdelkader Mami<sup>5</sup>

<sup>1,2,5</sup>University of Tunis El Manar, Laboratory Analysis, Conception and Command Systems (LACS-ENIT/FST-LR11ES20), Faculty of Sciences of Tunis (FST), Tunis, Tunisia

<sup>3</sup>University of Bourgogne, Laboratory DRIVE Nevers, France

<sup>4</sup>University of Lorraine Nancy, France

(<sup>1</sup>arafet200lit@gmail.com, <sup>2</sup>hatem.allegui@enit.rnu.tn, <sup>3</sup>elhassane.aglzim@gmail.com, <sup>4</sup>amar.rouane@univ-lorraine.fr, <sup>5</sup>abdelkader.mami@gmail.com)

**Abstract**-One of the problems for the fuel cells development is still the reliability of their performances over time. The solution of this problem is the implementation of an efficient diagnostic method such as that the use of the polarization curve measurement. To run a diagnostic, it is necessary to use a specific hardware and software tools for PEM fuel cells. It is very interesting to make real time instrumentation. In this work, we presented the description and developing steps of an application for measuring the polarization curve for PEM fuel cell. The results are obtained using a Nexa<sup>®</sup> Ballard PEM fuel cell, an electronic load and an application developed by LabVIEW<sup>®</sup> software and the microcontroller STM32F4.

**Keywords**- PEM Fuel Cell, Polarization Curve, Electronic Load, microcontroller STM32F4, Application LabVIEW<sup>®</sup> Software

## I. INTRODUCTION

Fuel cell is a transformer of chemical energy into electrical energy, so it is not a new technology and its working principle was discovered in 1839 [1] [2]. Currently, fuel cell is experiencing increased interest both industrially and research. The industrial sectors (transport, board electronics, and supply of energy in stationary ...) invest in the development of this technology. To use the fuel cell in a rational and efficient way, detailed knowledge of its constitution and its operation is required.

Fuel cell is an electrochemical device; its study requires multidisciplinary knowledge. The basic principle of the cell is the inverse of the electrolysis; the hydrogen combines with oxygen to produce electricity, water and heat. During the life cycle of a fuel cell, its performance tends to gradually deteriorate due to the chemical and physical changes of the cells involved in the use and function of his age until it more usable. The aging conditions of a fuel cell and associated mechanisms remain to understand, even if significant progress studies were conducted. In addition to aging, the performance degradation may also take place over a very short time scale due in particular to a clogging or drying of the membranes.

Such failures lead to reversible damage limited in time, which must be detected quickly to react via the system controller, so as not to lead to irreversible damage.

The measurement of the polarization curve of the fuel cell provides information on the evolution of the state of the cells making up the heart stack. This method allowing us to take measurements in real time during the operation of the fuel cell. This work is part of research project that is the study of PEM fuel cell over time depending on its use; it is to instrumentalize the PEM fuel cell.

## II. STUDY OF POLARIZATION CURVE FOR PEM FUEL CELL

### A. Description of the PEM fuel cell

The proton exchange membrane (PEM) fuel cell is the stack that has attracted significant interests of research and developments in the transport sector. It has several advantages over other fuel cells since its characteristics include operation at low pressures and temperatures ranges and a specific polymer electrolyte membrane. Thus, we will use this type of fuel cell in our work. The core of the PEM fuel cell is supplied with hydrogen and oxygen. The cell of a fuel cell is physically comprised of three main elements; the solid electrolyte is the membrane, the two electrodes composed of a diffusion layer with an active layer and two bipolar plates.

The principle of operation of the PEM fuel cell is based on the reverse process of electrolysis of water. A redox reaction (in the presence of platinum) reacting hydrogen and oxygen to produce electricity, water and heat in accordance with equations of the electrochemical reactions [2] [3] [4] [5] [6].

The anode reaction is (oxidation):

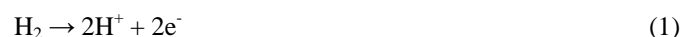

The cathode reaction is (reduction):



The chemical to electrical energy conversion is based on the electrochemical reactions taking place in the PEM fuel cell.

The fuel cell contains as electrolyte membrane Nafion. In the anode hydrogen decomposes (oxidation) into electrons and protons. The membrane that is impermeable to gases, only allows the hydrogen protons. The electrons are conducted from the anode to the cathode through an external circuit through an electrical load. At the cathode the oxygen combines (reduction) with the hydrogen protons and electrons to produce water and heat.

The theoretical potential ( $E_{rev}$ ) for the one cell of the PEM fuel cell is about 1.23 V in the standard conditions of temperature (25 ° C), and partial gas pressure (1 bar), it's the Nernst Law [7] [8]. When the fuel cell supplies a current flowing through an external circuit, the voltage across the fuel cell is lower than the theoretical potential ( $E_{rev}$ ). This is due to different voltage drops generally referred polarizations  $\eta$  (overvoltage) which is the activation polarization ( $\eta_{act}$ ), ohmic polarization ( $\eta_{ohm}$ ) and concentration polarization ( $\eta_{con}$ ). The expression of the voltage of a cell as follows:

$$V_{cell} = E_{rev} - \eta_{act} - \eta_{ohm} - \eta_{con} \quad (3)$$

Assuming that the parameters for the individual cells can be pooled and applied to present a stack of the fuel cell, the output voltage of the stack ( $V_{Stack}$ ) can be introduced as follows [9] [10]:

$$V_{Stack} = N_{cell} \cdot (E_{rev} - \eta_{act} - \eta_{ohm} - \eta_{con}) \quad (4)$$

$N_{cell}$  is the number of cells of the stack of the PEM fuel cell.

In this work, we used a Nexa PEM fuel cell from Ballard with a power of 1200W [11]. This fuel cell is a module that does not require maintenance, fully automated and highly integrated. The stack is composed of a total of 47 cells each capable of providing a load voltage of 26V to a maximum current of 46A and an open circuit voltage of 42V for a minimum current of 0.7A.

### B. Polarization curve of the PEM fuel cell

When the variation of an electric current across the fuel cell, a static characteristic is obtained, this characteristic provides the name of the direct current study or V-I characteristic. The principle of this method is to simultaneously measure the voltage and current delivered by the fuel cell, a voltage-current curve is obtained (polarization curve) which can be extracted various phenomena of the fuel cell. Fig. 1 shows the polarization curve of a PEM fuel cell.

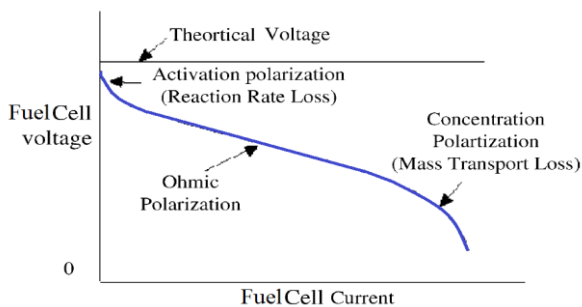

Figure 1. Polarization curve of a PEM fuel cell [12].

We can distinguish on the polarization curve also referred curve of V-I characteristic, three different zones:

- Activation polarization (Reaction Rate Loss).
- Ohmic polarization.
- Concentration polarization (Mass Transport Loss).

The activation polarization loss is due to starting of the chemical reactions at the anode and cathode. A portion of the available energy is used to break and re-form chemical bonds to the electrodes, this polarization increases with the current density of the fuel cell[13].This phenomenon occurs in low current values.

The ohmic polarization loss is due of the part the resistance of the flow of protons through the membrane and of the other part the electrons in the other elements of the assembly MEA (Membrane Electrode Assembly) of the cells which are generally prepared from carbon having high electrical conductivity, which means that the resistance of the membrane is greater than all other elements [14] [15]. This phenomenon present in the mean values of currents

The concentrations polarization loss is due to current draw by a load which results in a decrease of the concentrations of reactants and the diffusion of gases which occurs through the electrodes to achieve the reactions zones which depleted gas mixtures and decreases the partial pressure of gas. This loss becomes at higher currents when the fuel and oxidant are used at higher rates and the concentration in the gas channel is at a minimum [16]. This phenomenon occurs in high current values.

### III. DESCRIPTION AND DEVELOPMENT OF AN APPLICATION FOR POLARIZATION CURVE

This part of the work is a description of the different measurement mechanisms implemented for experimental data of the polarization curve. A test bench is made around the Nexa Ballard fuel cell and an electronic load carried by our own resources [17]. To this is added a measuring board based on the microcontroller connected to a computer to collect data that will be stored and processed by a measurement application developed with LabVIEW® software.

To implement this method, we must make measurements on the fuel cell during operation to the load, then the obligation to have an adjustable current load to multiply measurements at different value of the current supplied by the fuel cell.

Fig. 2 shows the picture of the test bench proposed; it describes the various stages that make up the electronic load, the control card and the acquisition module for measurement the polarization curve with STM32F4 microcontroller.

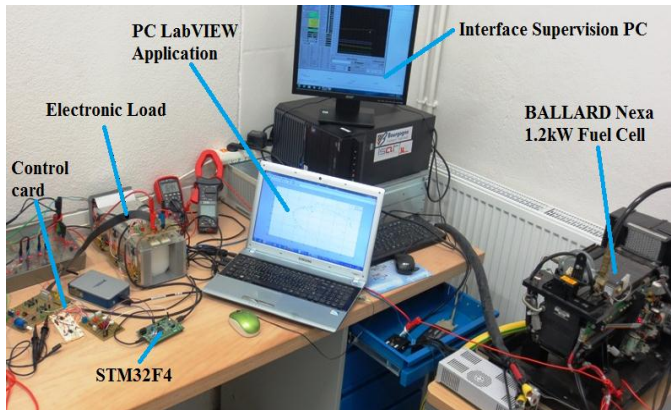

Figure 2. Picture of the test bench proposed.

The PEM fuel cell is that debits the current to be supported by the electronic load. The control card ensures the impose current to the control board of the electronic load to measure the data for the polarization curve, LabVIEW® is one that will save the results of the measurement through an acquisition module with STM32F4 to a file that can be used to view and compare the experimental results.

The design of this test bench is to process the signals of the voltage and current across the BALLARD Nexa PEM fuel cell to collect the data and draw the necessary diagrams of the V-I characteristic. The measurement module of our solution is based on a new microcontroller technology STM32F4 able to do complex calculations and manage the display of results via the USB through a graphical interface on a computer. This application consists of two main parts, the first part is for programming the microcontroller STM32F4 and the second part is for viewing and saving of results by LabVIEW®.

Fig. 3 represents the "Front Panel" of the application developed in LabVIEW® software to communicate the computer with the microcontroller STM32F4 to display and save the results of the V-I characteristic of the Nexa PEM fuel cell.

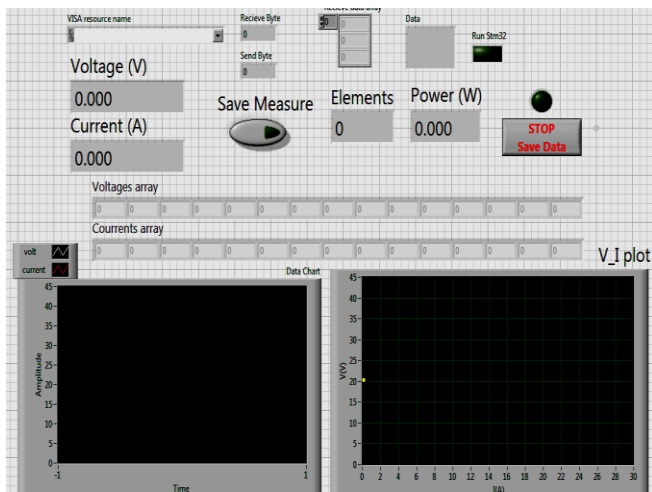

Figure 3. Front panel of the LabVIEW® application developed.

This LabVIEW® application is only used for displaying and saving different values obtained in a data file by the calculations of the microcontroller STM32F4.

Figure 4 shows the flowchart of the program developed in C language for microcontroller STM32F4 to plot the polarization curve.

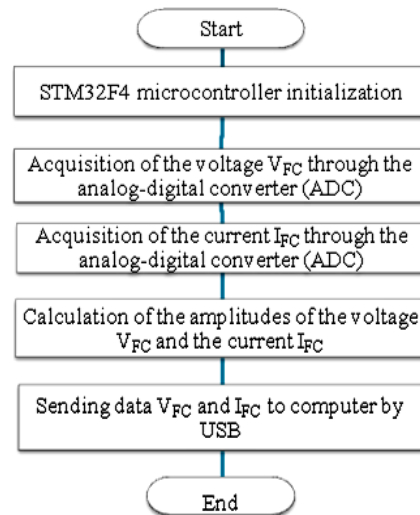

Figure 4. Flowchart of program C implemented in the STM32F4.

This flowchart shows the different procedures and functions of the measurement program of the voltage and current necessary for tracing the V-I characteristic by the microcontroller STM32F4.

The initialization will be the selection of hardware devices needed for this application, the next step is to acquire by the analog-digital converter the voltage and current across the Nexa fuel cell. After obtaining the different values by the analog-digital converter, the microcontroller STM32F4 launch the procedure for calculating the amplitudes of numeric values. Finally, when the microcontroller completes these calculations, it sends the results obtained by the USB for display by the LabVIEW® application. This application allows us to visualize in real time the variation of different values of the voltage and current from the samples taken by the STM32F4 on the Nexa PEM fuel cell.

#### IV. THE RESULTS AND DISCUSSION

The test bench is proposed for instrumentation dedicated to the fuel cell. For this, the final confirmation of this design is provided by tests on Nexa fuel cell. We started testing by tracing the polarization curve or V-I characteristic of Nexa PEM fuel cell using the proposed electronic load and the application developed by STM32F4 and LabVIEW®.

The TABLE I. shows the measured values of voltage and power of the NEXA fuel cell versus current. We presented in this table the experimental values of the voltage and power of

the Nexa fuel cell to a current range of 0 to 25A in steps of 1A between two successive measured values.

TABLE I. MEASURED VALUES OF CURRENT, VOLTAGE AND POWER FROM THE NEXA FUEL CELL.

Current $I_{FC}$ (A)	Voltage $V_{FC}$ (V)	Power $P_{FC}$ (W)
0.14	40.18	5.52
1.04	39.05	40.47
2.02	37.83	76.34
3.01	36.99	111.39
4.03	36.02	145.07
5.05	35.56	179.44
6.01	35.23	211.74
7.02	34.89	244.83
8.01	34.38	275.24
9.00	34.08	306.91
10.08	33.58	338.55
11.03	33.28	367.16
12.00	32.90	394.91
13.06	32.52	424.82
14.02	32.10	449.95
15.05	31.79	478.42
16.04	31.50	505.13
17.01	31.20	530.77
18.04	30.74	554.49
19.01	30.44	578.81
20.01	30.22	604.83
21.02	29.95	629.58
22.08	29.52	652.01
23.02	29.24	673.10
24.06	28.83	693.52
25.02	28.53	713.98

Figure 5 represents the waveform of the polarization curve of the Nexa PEM fuel cell. The principle of this test is to measure and save simultaneously the voltage, power and current delivered by the fuel cell using the application developed by STM32F4 and LabVIEW®.

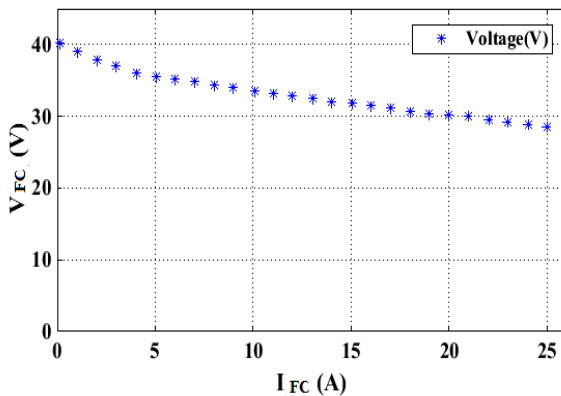

Figure 5. Polarization curve of the Nexa PEM fuel cell.

It is observed in this curve two distinct areas; one for the low current corresponds to a voltage drop due to the activation overvoltage caused by the electron transfer to the cathode area and the second means for matching a current ohmic drop localized mainly in the membrane [18]. There is a third area that corresponds to high currents, it does not appear in this curve corresponding to a voltage drop due to the problems of reactant diffusion limited by the mass transport which causes a sudden drop in the fuel cell voltage.

Fig. 6 represents the waveform of the power curve of the Nexa PEM fuel cell.

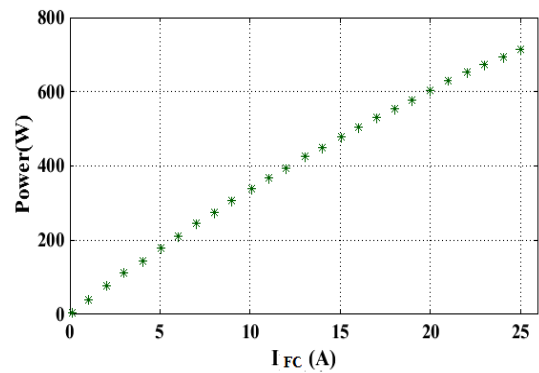

Figure 6. Power curve of the Nexa PEM fuel cell.

We observe that the increase is linear to the current until achieve maximum power delivered by the fuel cell. The power begins to decrease in the area that corresponds to the high current, as this area is not on the curve, this is due that the electronic load cannot exceed the power of 750 W, this is also due to the safety of the Nexa control card system that intervenes when we reach maximum power in order to protect the elements of the fuel cell system.

The shape of the polarization curves of these tests is in various researches [6], [19], [20] which confirms these tests and validates our design of both applications developed by STM32F4 and LabVIEW® software. Fig. 7 shows an example of polarization curve for Nexa fuel cell used by W. H. Zhu et al [20].

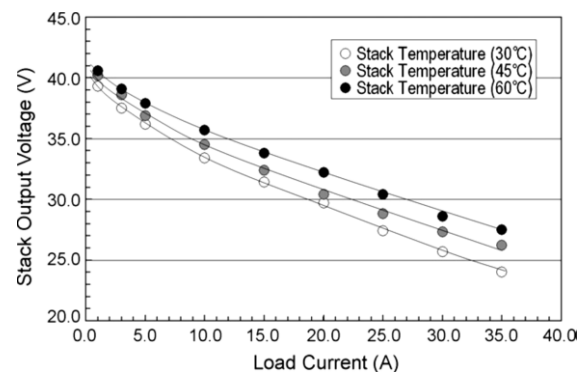

Figure 7. Example of Polarisation curve of a Nexa PEM fuel cell found in other research [20].

We note that our results join the results found by these researchers. They used a fuel cell of the same family is the Ballard Nexa fuel cell and a measurement test bench Gamry that Gamry FC350™ is a tester which integrates an industrial electronic load and system for measuring and displaying the polarization curve.

Fig. 8 shows a comparison between the polarization curves of the Nexa fuel cell realized in 2013 and 2015.

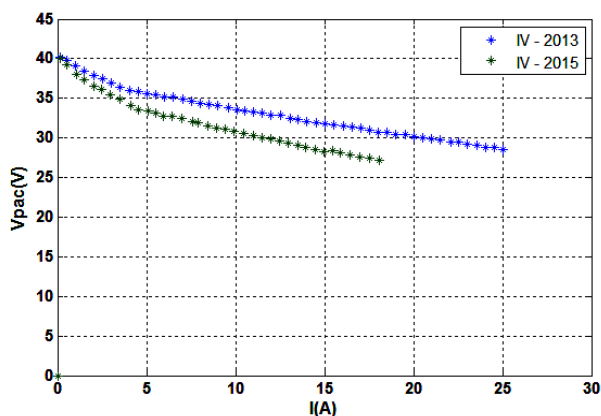

Figure 8. Nexa fuel cell polarization curves in 2013 and 2015.

The aging of the Nexa PEM fuel cell is mainly caused by the aging of the membranes - electrodes assembly (MEA). This phenomenon is observed by the degradation of the voltage to a nominal current imposed in the ohmic region. About the two curves, we observe the same open circuit voltage value in the activation zone, but by increasing the current the ohmic region is varied during time. This variation is caused by the phenomena of the apparent decline in catalytic activity, lower transfer speeds of matter and the fall of the ionic conductivity of the membrane [19].

## V. CONCLUSION

In this work, we have used the STM32F4 and LabVIEW® software to develop an application for measuring data, tracing and displaying the polarization curve. This application allows us to avoid the use of industrial equipment that is expensive and cumbersome. We found the same experimental results with the use of industrial equipment.

## ACKNOWLEDGMENT

This work was supported by the Faculty of Sciences of Tunis (FST) in Tunisia, the DRIVE laboratory of the ISAT at Nevers in France and Institute Jean Lamoure at Nancy in France.

## REFERENCES

- [1] H. Oman, "Fuel Cells Personal Electricity", IEEE AES Systems Magazine, September 2000.
- [2] 2013 Fuel Cell Technologies Market Report: Fuel Cell Technologies Office, U.S. DEPARTMENT OF ENERGY, November 2014.
- [3] S. Litster and G. McLean, "PEM fuel cell electrodes", Journal of Power Sources, vol 130, pp : 61-76, 2004.
- [4] M. BOILLOT, "Experimental validation of modeling tools of a PEM fuel cell", Thesis, Institut National Polytechnique de Lorraine, France, 2005.
- [5] A. THOMAS, "Water and heat transfer in a membrane fuel cell: experimental demonstration of coupling and analysis of mechanisms", Thesis, Institut National Polytechnique de Lorraine, France, 2012.
- [6] E. Laffly, M.-C. Pera, and D. Hissel, "Polymer electrolyte membrane fuel cell modelling and parameters estimation for ageing consideration," in Proc. IEEE ISIE, 2007, pp. 180-185.
- [7] O.RALLIERES, "Modeling and characterization of PEM Fuel Cells and electrolyzers", Thesis, Université de Toulouse, France, 2011.
- [8] G.H. Guvelioglu, H.G. Stenger, "Computational fluid dynamics modeling of polymer electrolyte membrane fuel cells", Journal of Power Sources, Vol. 147, Issue1-2, pp 95-106, Septembre 2005.
- [9] N. Benchouia, A.E. Hadjadj, A. Derghal, L. Khochemane and B. Mahmah, "Modeling and validation of fuel cell PEMFC". Revue des Energies Renouvelables Vol. 16, N°2, pp. 365 - 377, Alegria 2013.
- [10] C. Wang, M. Nehrir and S. Shaw, "Dynamic Models and Model Validation for PEM Fuel Cells Using Electrical Circuits", IEEE Transactions on Energy Conversion, Vol. 20, N°2, June 2005, pp.442 - 451.
- [11] Nexa Power Module User's Manuel, Ballard Power Systems, 2003.
- [12] D. Yu, S. Yuvarajan, "Electronic circuit model for proton exchange membrane fuel cell", Journal of Power Sources, 142, p. 238-242, 2005.
- [13] H. BEKKOUCHE, "Numerical study of phenomena of heat transfer and mass in PEM fuel cell.", DEA, Université de Constantine 1, Faculté des Sciences Exactes Algérie, 2014.
- [14] M. Sadiq Al-Baghdadi, "Modelling of Proton Exchange Membrane Fuel Cell Performance Based on Semi-Empirical Equations". Renewable Energy, Vol.30, N°10, pp. 1587 - 1599, August 2005.
- [15] W.Q. Tao, C.H. Min, X.L. Liu, Y.L. He, B.H. Yin and W. Jiang, "Parameter Sensitivity Examination and Discussion of PEM Fuel Cell Simulation Model Validation Part I. Current Status of Modeling Research and Model Development". Journal of Power Sources, Vol. 160, N°1, pp. 359 - 373, September 2006.
- [16] D. Chu, R. Jiang, C. Walker, "Analysis of PEM fuel cell stacks using an empirical current-voltage equation", J. Appl. Electrochem.30 (2000), 365-370.
- [17] A.Bouaicha, H.Allegui, A.Rouane, E.H.Aglzim and A.Mami, "Design and Realization of an Electronic Load for a PEM Fuel Cell". World Academy of Science, Engineering and Technology, International Science Index 85, International Journal of Electrical, Electronic Science and Engineering, Vol:8 No:1, pp 202 - 207, 2014.
- [18] J.Deseure, P-X. Thivel ,M.Marchesiello, "Methods for characterization of a fuel cell", Publication Notes, Université Joseph Fourier de GRENOBLE, CNRS, France ,2008.
- [19] P.Massonnat, F.Gao, D.Bouquain, et A.Miraoui, "Synthesis on aging of PEM fuel cell", Journal of latex class files, VOL. 11, NO. 4, December 2012.
- [20] W.H. Zhu, Robert U. Payne, Bruce J. Tatarchuk, "Equivalent circuit elements for PSpice simulation of PEM stacks at pulse load", Journal of Power Sources, 178, pp. 197-206, 2008.