



DESIGNING AN OFF-ROAD WORKING LAMP WITH LEDS

Celal Zaim ÇİL¹, Burcu YAKIŞIR²

^{1,2} Cankaya University, Electronic and Communication Engineering Department, Eskisehir Yolu 29.km, 06810, Yenimahalle, Ankara, Turkey

czaimcil@cankaya.edu.tr, yakisirburcu@hotmail.com

Abstract: In this study a working lamp used on the off-road working machines and vehicles is designed by using the LED diodes instead of a halogen bulb. In the design, firstly a LED array is determined and a proper driver circuit that can provide the required optical power is designed, and the working lamp developed is tested under various conditions. The luminous output values of the designed LED working lamp are compared with those of a commercial working lamp, which uses a halogen bulb. It is evaluated that in automotive applications lamps using LEDs could be successfully utilized depending on the optical efficacy of the LED used, the designs of the LED driver and the reflector.

Key Words: High power LED, LED Driver, LED lamp, Luminous flux, Optical Output Power

1. Introduction

Light emitting diodes (LEDs) have been extensively used in lighting and illumination applications in recent years due to the improvements in technologies like semiconductor manufacturing, electronic and packaging. The improvements in LED drivers and in cooling techniques for electronic circuits have also catalized the already existing conditions that have made this development of LEDs a reality. Today, in addition to their classical roles as signal transmitter-receiver in remote controllers and as indicating or decorating elements in electrical circuits, LEDs have found much wider applications in traffic signs, street lightings, automotive lightings, in various indoor and outdoor luminaire applications, in backlighting the portable devices such as mobile phones, netbook, and slim LCD, organic LED (OLED) televisions, and displays. Recently very powerful white LEDs have been manufactured with reasonable costs. These LEDs have been used to replace the incandescent, halogen and fluorescent lamps in lighting applications. LEDs are about 50% more power efficient than incandescent and halogen lamps. Under suitable conditions an LED's life could reach 50.000 hours, which means nearly 34 years of normal use for a lamp. However, this property could not be fully utilized. An LED should be driven properly to emit desired light intensity in the correct wavelength, i.e., color. To provide the desired current we need to use

a driver circuit with an LED. Thus, the life of the whole lamp system, namely the LED and its driver circuit, would be certainly limited by the life of the driver, which is about 10.000 hours. In this work we developed a prototype off-road working lamp using an LED array that would provide the same optical power with the existing halogen lamp. This working lamp could be used on an off-road working machine to illuminate its working area as required. The illumination characteristics of the prototype LED lamp developed are compared with a commercial halogen working lamp.

2. LED Operation

An LED is basically a pn junction diode, which is basically formed when n-type and p-type semiconductor materials make a junction. The semiconductor materials are chosen as direct-bandgap semiconductors for the LEDs. When the LED is forward biased and a forward current passes, light is emitted from the device. The energy bandgap (E_g) of the semiconductor material determines the frequency (ν), i.e., the color, and the energy ($E = h\nu$) of the photon emitted, h is Planck constant here. Recent developments in material sciences and manufacturing technologies have made obtaining LEDs emitting light in the spectrum ranging from infrared (IR) to ultraviolet (UV) wavelengths possible. The photon generated by the

LED is due to the recombination of an electron in the conduction band with a hole in the valence band of the semiconductor. The recombined electron and hole are called an electron-hole pair (EHP). When a free electron in the semiconductor material (an electron in the conduction band) becomes bound to an atom fixed in the material (filling a hole, becoming a bound electron in the valence band), the energy lost by the free electron is generally equal to the energy bandgap of the material in a direct bandgap semiconductor. This energy is transmitted mostly as a photon. This mechanism of generating light is called electroluminescence. In indirect bandgap semiconductors, however, the energy lost by the recombining EHP is mostly given off as heat to the material. When there is no extrinsic excitation to the LED, that is when the LED is in thermal equilibrium, some EHPs recombine randomly and ultimately the number of photons generated is negligible. However, when too many EHPs are injected into the LED by an outside excitation the rate of recombination of EHPs and therefore, the rate of generation of photons increases enormously and the intensity of the light emitted from the LED becomes noticeable. There are many charge carriers, mainly free electrons (n) and holes (p) in the n - and p -regions of semiconductor, respectively, at room temperatures normally. When the LED is biased in the forward direction these free charge carriers will move into the opposite region under the influence of the electric field generated by the bias. The net charge transfer through the cross section in time generates a current from p to n -region, which is called the forward-current, I_f . The forward current carries the EHPs to the junction region of the LED oppositely from both sides, where they meet, recombine and generate the photons. If a constant forward current passes photons are generated in a constant rate in an LED. Since the photons emitted by the LED are of generally a constant energy approximately equal to the bandgap of the semiconductor, the spectrum of the light generated by a LED occupies a narrow range of about 20 nm on the wavelength axis. Therefore, their colors are considerably pure [1, 2, 3, and 4]. Not all of the recombining carriers give off their energy as photons even in the direct bandgap semiconductors. Some of the energy lost by recombination is transferred to the semiconductor as heat. Also, not all of the photons generated in the diode can find a way to get out of the semiconductor material and is transmitted. A quantum efficiency that relates the number of the transmitted photons and the number of generated

photons, η_{ex} , is given as,

$$\eta_{ex} = \Phi_0 / \Phi \quad (1)$$

where Φ_0 is the output photon flux (number of

photons transmitted per second), and Φ is the internal photon flux (number of photons generated per second). The forward current I_f ,

$$I_f = nqvA \quad (2)$$

where n is the number of charge carriers in a unit volume, q is the unit charge, v is the velocity of carriers, and A is the cross sectional area of the junction. The number of photons generated by the recombining EHPs in a second is given as,

$$\Phi = \eta_i N \quad (3)$$

, where η_i is the internal efficiency of recombining carriers to generate photons, N is the number of carriers recombining in a second [4],

$$N = I_f / q. \quad (4)$$

Then,

$$\Phi = \eta_i I_f / q \quad (5)$$

is obtained. Actually I_f / q is the injected photon flux by the forward current. The output, i.e., transmitted, photon flux is then

$$\Phi_0 = \eta_{ex} I_f / q. \quad (6)$$

η_{ex} is a single quantum efficiency, the external efficiency, that accommodates both of the processes,

i.e., $\eta_{ex} = \eta_e \eta_i$ which can reach 50% [4]. The LED

output optical power P_0 , is then obtained by the product of the photon flux and the photon energy $h\nu$ [4]

$$P_0 = h\nu \Phi_0 = \eta_{ex} h\nu \frac{I_f}{q}. \quad (7)$$

The optical output power is directly proportional to the forward current. We control the optical output power of an LED by controlling its forward current. Figure 1 shows the relative luminous flux versus forward current in a power LED (actually the figure is taken from the manufacturer's datasheet of the LEDs we use in this work) which confirms (7) to a great extent [5]. The optical output power would not increase with the increase of forward current indefinitely; as the forward current increases the efficiency of the LED decreases. The luminous flux is the part of the optical power (or sometimes called as the radiant power), which is composed of the photons of the wavelengths within the visible range of the human's eye only. LEDs also have a very

quick response time (about 20 ns) and instantaneously reach full light output [3]

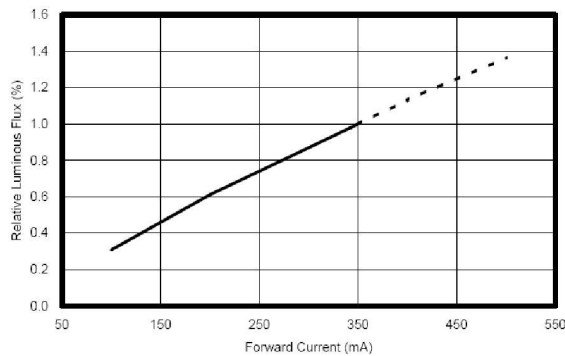

Figure 1. An LED's luminous flux versus forward current [5]

3. LED Drivers

Today high power LEDs of having 10-20W (at 555 nm 1W=683 lumens) of optical output powers are available on the market. These LEDs are being used in street lighting, automotive lighting, and traffic signalling applications. When used in such applications a number of LEDs are connected in series and parallel configurations to increase the total optical output power of the lamp, provide a reliable operation and extend the illuminated area. When connected in series configuration the LEDs

will have the same forward current, I_f , and within small manufacturing tolerances they will provide the same optical output power. If the electrical power source is available, increasing the number of LEDs connected in series will increase the total optical power. The main disadvantages of series connection of the LEDs are the relatively lower operation reliability and the requirement of higher voltage values from the power supply, the driver, when the number of series LEDs increases. The reliability is not good for series configuration; because when any of the LEDs becomes open circuited the total circuit breaks down. When LEDs are connected in parallel, each LED draws its own current from the driver and the total current to be supplied by the driver increases. In parallel configuration since the LEDs'

forward voltages, V_f , are not exactly the same due to the manufacturing tolerances, each LED's operating point is different from the others, and it

draws a different forward current, I_f , and therefore, each LED's optical output would be slightly different. The advantage of parallel connection is that when a LED breaks down, generally becomes open-circuited, this time not the whole system collapses but the other LEDs continue to operate. The total current drawn from the driver will be the

sum of the individual forward currents of the LEDs in parallel. High power LEDs could draw currents up to a few Amperes as can be seen in Figure 1. Since generally a number of LEDs are used in designing a lamp the LED driver circuits are required to provide the total forward voltage and forward current at the same time. A lamp using LED as light source almost always includes the LEDs and a proper driver circuit to provide the required voltage and the current needed by the LEDs. When we consider that a high power LED has a useful lifetime of 50.000 hours and at least two times as efficient as halogen lamps [6], for the lamp to utilize these advantages the LED driver circuits should be reliable enough. In addition to this, a LED driver should not consume much power in order not to reduce the efficiency of the lamp as a whole system. When LEDs draw large currents they get heated due to their internal resistance and the transfer of the energy of some of recombining carriers as heat to the semiconductor. Therefore, the LED drivers should be designed such that they also prevent (to the extent possible) the LEDs from heating and/or some cooling means should also be considered. Together with the increasing demand of use of LEDs in high power applications, these requirements on the LED drivers have been recognized by the industry and recently many capable integrated circuit (IC) LED drivers of small sizes and low prices were introduced into the market. Most of these IC LED Drivers control the average LED forward current by switching generally a power metal-oxide semiconductor field effect transistor (MOSFET) to energize an inductor and transfer the energy stored into a capacitor when switched and ultimately transfer this energy to a LED array. Keeping LED's average current constant guarantees a constant optical power output. Arranging the level of the average current (dimming) is done by controlling the duty cycle of the switching i.e., applying a pulse width modulation (PWM) signal to the gate of the power MOSFET with a relatively high frequencies (about 100 kHz). However, in the applications like automotive lighting, such high-frequency current-voltage pulses may cause electromagnetic interference (EMI) with the other electronic equipment on the vehicle. To prevent these effects, some techniques like filtering, and screening should also be used in the design of the LED drivers.

LED Driver circuits can be classified into two [3, 7-14]:

Linear LED Drivers: In this type driver, the output voltage is always less than the input voltage. The difference between input and output voltage drops mainly on the transistor or the regulator circuit that provides also the output current for the LEDs. Hence

a considerable amount of power is wasted on the regulator as heat. There will be no PWM application. These drivers need heat sinks, which increase the weight, volume and the cost. As the difference between input and output voltages increases the efficiency of the driver gets worse. However, they introduce no EMI problems. IC LM317A is a good example to these regulators.

Switching LED Drivers: These drivers provide the required voltage and current with a switched MOSFET and a proper L and C combinations, utilizing a PWM for dimming. There are three types of switching LED drivers:

Buck LED Drivers: The output voltage is always lower than the input voltage. They could attain a power efficiency level of 98%. Examples to these drivers are Supertex HV9910, and National Semiconductor LM 5020.

Boost Converters: The output voltage is higher than the input voltage. They could attain a power efficiency level of 90%. Examples to these drivers are Supertex HV9912, and Linear Technology LTC.

Boost-Buck Converters or Single-Ended Primary Inductance Converter (SEPIC):

The output voltage can be lower or higher than the input voltage. They could easily attain a power efficiency level of greater than 85%. Examples to these drivers are Supertex HV9930, and AT 9933. Input and output of these drivers are isolated by a capacitor. It could be sometimes difficult to stabilize these drivers.

4. Designing the Off-Road Lamp with LEDs

In this work we design a working lamp for an off-road vehicle by using LEDs to replace an existing commercial halogen working lamp. Our objective is to design a lamp by using the LEDs that consumes a power less than a typical halogen working lamp (55W), provides the same optical output power and illumination as that halogen lamp, operates properly for the input voltages of 12-48V, up to 75°C of ambient temperatures, and with a material cost less than 20€. The design process starts with selecting the proper LEDs among those available in the market. The LEDs are desired to provide the maximum power efficacy with the lowest cost. Under these circumstances, the LEDs from Edison Opto Corporation (Edixeon EDEW-1LA5-D1 natural white Series) that can provide an efficacy of 40 lumens/W (optical power) at white color (cool white) with $I_f = 350 \text{ mA}$ at the junction temperature

of 25°C of a unit price 1€ were selected due also to the reasons that they are available at the local market and used by the automotive sector [13]. The commercial halogen lamp's manufacturer informed us that the halogen lamp has the luminous flux of approximately 529 lumens. The LED lamp to be designed should at least provide this luminous flux. To attain this luminous flux value we have to form an array with the LEDs we have selected. However, Figure 2 shows that at the ambient temperature of 75°C the highest forward current of an LED becomes $I_f = 200 \text{ mA}$, and the luminous flux around this forward current value decreases to 60% of its value for $I_f = 350 \text{ mA}$, as can be seen from Figure 1. A 200mA forward current corresponds to the luminous flux of about 24 lumens (60% of 40 lumens).

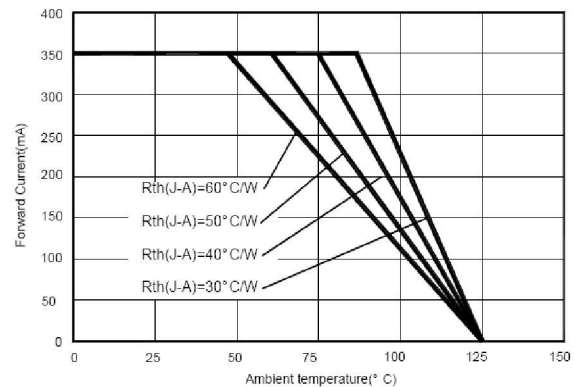

Figure 2. The change of the forward current of the LED when the ambient temperature increases [5]

To obtain 529 lumens at ambient temperature of 75°C we need to use 22 LEDs in the array and drive each of them with a forward current of 200mA. Unfortunately, this will exceed our cost ceiling of 20€ targeted. Under these conditions and with the LEDs available it is not possible to build the desired lamp operating at an ambient temperature of 75°C without a heat sink. We do not want to use a heat sink because it makes the lamp clumsy and expensive. As a result, we give up meeting the requirement of operation at 75°C by considering that the LEDs would not normally operate under this condition. Instead, we aim to make the design such that the LEDs do not exceed the junction temperature of 75°C, which can be met by this type of LEDs. It is seen from Figure 2 that under the ambient temperature of 50°C, the LEDs can operate with $I_f = 350 \text{ mA}$ and each can provide approximately 40 lumens. For this case the minimum luminous flux requirement of the lamp (529 lumens) can be attained by at least 14 LEDs.

To be on the safe side and to have a symmetric array of LEDs we decide to use 15 LEDs in our lamp. The maximum luminous intensity can be achieved with 15 LEDs is 600 lumens in this case. Having somewhat higher luminous flux value (600 lumens versus 529 lumens) in the lamp design is also supported by the considerations that an LED's wall-plug efficiency (lumen/electrical power) decreases in time of use and with the temperature increase, and at the same time by using 15 LEDs the cost target is still not exceeded [15]. 15 LEDs would cost 15€, and we have still 5€ left for the printed circuit board (PCB) and the LED Driver. We decide to use a buck type LED Driver because they are very efficient and

inexpensive [3]. LEDs forward voltages, V_f , under the operating conditions cited above are given in their datasheet as 3.1V-4V [5]. Since the minimum voltage input supplied by the electricity power system of the off-road vehicle (working machine) is given as 12V and the expected value is around 13.5V, with a buck type LED driver we could use at most 3 LEDs in series connection in the array. In accordance with this, an array of LEDs of 5 parallel columns with 3 LEDs in series in each column is formed. The circuit of the lamp is given in Figure 3. The PCB and LEDs are organized and implemented for the lamp as shown in Figure 4. For the LEDs to dissipate the heat generated more effectively we prefer to use an aluminium printed circuit board (PCB). A Supertex HV 9910 IC is selected for establishing the LED Driver with an n-channel power MOSFET [11-14]. In the array the total current to be supplied to 5 parallel LED columns will be 1.75A.

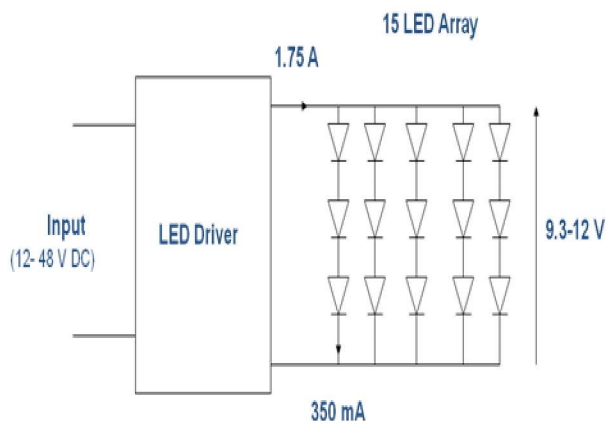

Figure 3. The circuit of the lamp with LEDs



Figure 4. The LED array on the PCB (5 parallel columns of 3 series LEDs on an aluminum PCB, the LED driver is at the back of the PCB)

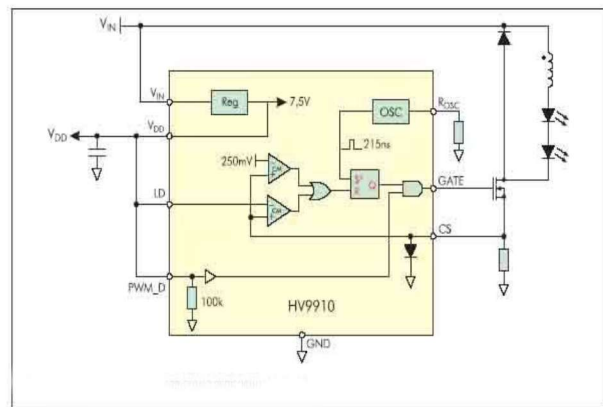

Figure 5. The buck type LED Driver with PWM capability [11]

To direct and distribute the light rays generated by the LEDs we use the lenses as seen in Figure 4. These lenses are selected to provide the required illumination distribution and intensity levels ($\text{lux} = \text{lumen/area}$). We measured the light intensity of the lamp designed in accordance with the standard of Commission Internationale de l'Éclairage 127 (CIE-127) ILED-B [16]. The measurement set-up is shown in Figure 6.

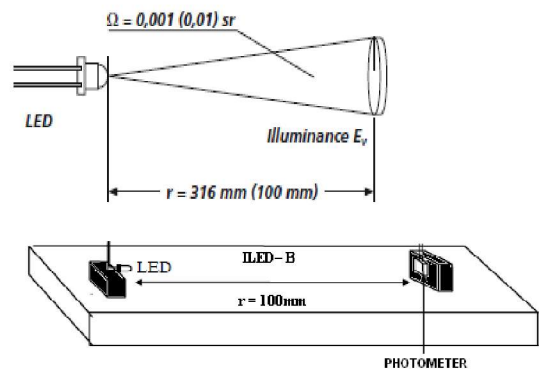

Figure 6. The light intensity measurement set-up for the LED array (CIE-127) [16]

The LED light intensity measurements were made in darkness at the room temperature ($22^{\circ}C$) by using the photometric sensor head with a Delta OHM photometer. The measured light intensities versus forward current of LED array, $(E_v - I_f)$, are plotted in Figure 7.

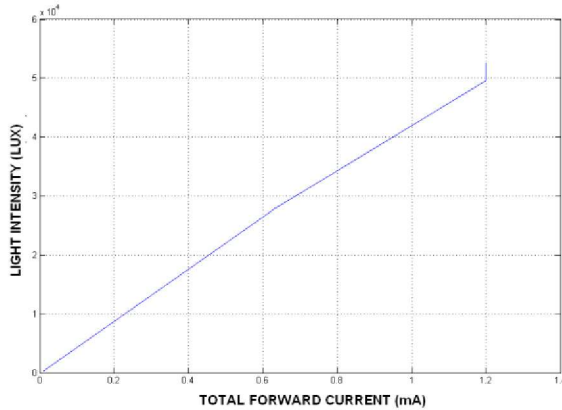

Figure 7. Measured light intensities of the LED array against the total forward current of the LED array

The behavior in Figure 7 complies with the expected LED's light intensity versus the forward current. The intensity measurements were made in relatively short times (around 10 seconds) in order not to change the junction temperatures of the LEDs. Since there is no method defined yet to derive the luminous flux values from the LED's light intensity measurements based on the CIE 127 standard, we were not able from this measurement to derive and therefore to decide whether the luminous flux value of the LED lamp meets the requirement.

The photometric luminous flux values of the designed LED lamp were obtained from the measurements of light intensities at the distance of 3.16m and 25m by using a goniophotometer with three-axes motion capability in accordance with the standard techniques and were compared with those of the commercial halogen lamp. The results derived from measurements are given in Table-1 and Table-2 [17]. In the measurements a horizontal scanning in the range of -40° and $+40^{\circ}$ is made with steps of 0.5° , and vertically in the range of -30° and $+30^{\circ}$. During the measurement an input voltage of 13,5V is applied and the lamps are kept under dark at $22^{\circ}C$. The total light intensities in the scanned range are given for both lamps (LED and halogen) in Figure 8, where the levels of intensities are denoted by color shading as defined.

Table 1. Maximum light intensities of the lamps at distances of 25m and 3.6m from the light sources

Distance from the light source=25m		
	Halogen Lamp	LED Lamp
IoS	2.73 luxes	4.07 luxes
BVI	12.49 luxes	23.69 luxes
IDS	12.49 luxes	23.69 luxes

Distance from the light source=3.16m		
	Halogen Lamp	LED Lamp
IoS	154.41 luxes	244.85 luxes
BVI	11.55 luxes	22.93 luxes
IDS	11.55 luxes	22.93 luxes

IoS: Illumination on the screen, **BVI:** Bird view illumination, **IDS:** Illumination that driver sees

Table 2. Total luminous fluxes for the lamps in the scanned range

Halogen Lamp	LED Lamp
529.72 lumens	421.98 lumens

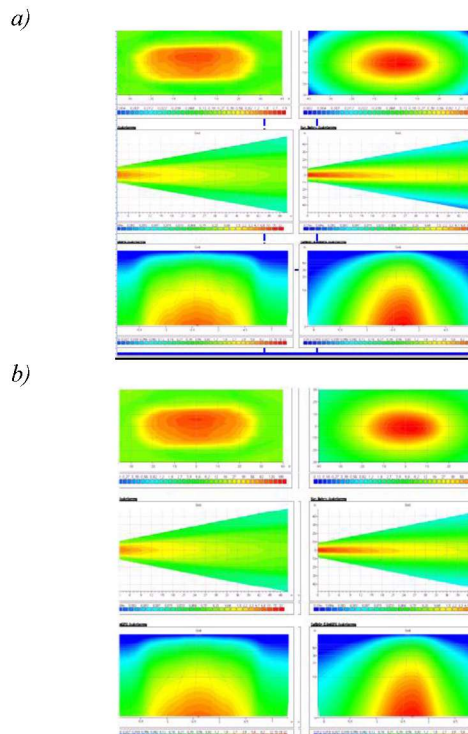

Figure 8. Total light intensities of the halogen lamp (left) and the LED lamp (right) in the scanned range for 25m (a), and for 3,16m (b)

It is seen from the tables and figures that the LED lamp and the commercial halogen lamp have quite close light intensity and luminous flux values. It is seen that the LEDs couldn't provide the total luminous flux of 600 lumens as expected (40 lumens at $I_f = 350$ mA for each LED). This would prevent the LED lamp mostly from reaching the desired light

intensity and luminous flux values and distributions. Luminous flux is measured to be 422 lumens in the scanned range. This lower than expected lumen value of the LED lamp is mostly due to the heating of the LEDs at $I_f = 350 \text{ mA}$ forward current level. When LEDs are heated their light efficiency and efficacy will decrease [3, 4, and 15]. In this case, we can either use a heat sink and reduce the junction temperature of the LEDs and further increase the forward current or use better LEDs with higher light output for the same forward current (higher efficiency and efficacy). Naturally the second solution is better. A heat sink is heavier and causes the lamp to become more clumsy and expensive. Fortunately, the improvements in the LEDs are fast and LEDs with higher efficacies are being manufactured and introduced into the market daily [18]. If the power LEDs of higher efficacies in the market were available we could achieve the required illumination characteristics for the lamp staying within budget. As a result, it is understood that in a very short time the desired lamp light output power and illumination distribution characteristics can be attained with the advances in the LED technology and manufacturing. Therefore, the commercial halogen lamp can soon be replaced by a LED lamp having a better illumination characteristic with a lower cost. By considering the rates of improvement in the LED and Driver technologies and manufacturing, if we also add the development in the optical and reflector design techniques, in nearly all of the automotive and lighting applications LED lamps will surely dominate the market soon.

5. Conclusions

In this work, to replace the less efficient and short-life halogen working lamps used in off-road working machines and vehicles, a more power efficient and long-life lamp is designed by using high-power LEDs. There are many ways of realizing the design for the lamp with LEDs. In this work we form a LED array with 15 1W-cool white LEDs on an aluminium PCB by connecting 3 LEDs in series with 5 parallel lines. This array of LEDs is driven with a buck type LED Driver circuit formed by using a HV 9910 IC with an n-channel power MOSFET. The luminous flux and light intensity values and their distributions within a certain volume in front of the lamp are measured. These measured values and their distributions for the LED lamp are compared with those of a commercial halogen lamp. It is seen that the results of the measurements are very close for the two lamps. We observe also that the alignment of the LEDs in a proper geometry, and using the right combinations of the reflectors and lenses are also important in

achieving the desired light output. We conclude that the most important parameter in the design of the lamp with LEDs is the light efficacy and efficiency of the LEDs. The use of LEDs in place of incandescent, halogen and fluorescent lamps are getting wider each day. Increasing light efficiencies and efficacies in the new high power LED technology and manufacturing will surely make them more appropriate in many light applications.

6. References

- [1] E. Musayev, "Semiconductor Light Sources' Connection and Biasing Methods", Uludağ University, Journal of Engineering and Architecture, Vol. 10, No.2, pp. 63-78, 2005.
- [2] E. Musayev, "Investigation of Homogeneity of the LED Light, Illumination", Electronic, Automation, Energy, Journal of Machine and Control Systems, No. 118, 190-195, 2004.
- [3] S. Winder, "Power Supplies for LED Driving", Elsevier Science, Boston, MA, USA, 2008.
- [4] B.E.A. Saleh, M.C. Teich, "Fundamentals of Photonics", Wiley- Interscience, Hoboken, NJ, USA, 2007.
- [5] Edixeon Dx, Ex Series LEDs, "Application Notes", Edison Opto Corporation, USA, 2008.
- [6] M. Hansen, "LED lighting: more energy efficient than CFL", Energy-efficient lighting lifecycle-white paper, Cree Inc., USA, 2009.
- [7] B. Weir, "Trends and Tradeoffs in Powering LED Luminaire", LED Journal, pp.8-11, Nov-Dec 2008.
- [8] E. Hoyt, "Driving LEDs in the Automotive World", LED Journal, pp.15-17, Nov-Dec 2008.
- [9] E. Uiga, Prentice Hall, "Optoelectronics", New Jersey Columbus, OH, USA, 1995.
- [10] M. Calvert, "LED Driver Applications for Portable Products", AN-23 Microsemi Integrated Products, USA, 2000.
- [11] K. Curtis, "Buck Configuration High-Power LED Driver", AN874, Microchip Technology Inc, USA, 2003.
- [12] *Constant, Off-time, Buck-based, LED Drivers Using the HV9910B*, Application Note, AN-H50, 2009.
- [13] *Luxeon Star, Basic Driver Circuits for Evaluating Luxeon LEDs. Application Notes*, Electrical Drive Information Luxeon Emitter, App. Notes AB11L, 2004.
- [14] A. Mednik, "Automotive LED Lighting Needs Special Driver", Supertex Inc. Sunnyvale, CA, USA, 2005.
- [15] G. Held, "Introduction to Light Emitting Diode Technology and Applications", CRC Press, Boca Raton, FL, USA, 2009.
- [16] *CIE Statement on Energy Conservation and Lighting*, Publication CIE, No.29, 1975.
- [17] A.K. TÜRKÖĞLU, F. SAMADOV, M. DURAK, U. KÜÇÜK, "Otomotiv Sektöründe Optik Test ve Ölçümün Yeri", III. Ölçüm Bilim Kongresi Bildiri Kitapçığı, Eskişehir, 1999, s. 140- 145.
- [18] *Cree Products'Xlamp "XP-G" datasheet*, Application Notes, 2010.



Celal Zaim ÇİL received the B.Sc., M.Sc. and Ph.D. degrees in Electrical and Electronic Engineering in 1982, 1984, and 1989, respectively, in Bogazici University, Istanbul, Turkey. He worked as Lecturer in Air Force Academy, Istanbul, Turkey until 1994. He then worked as an engineer in NAPMA, NATO,

Brunssum, Holland in 1994-97, and as a manager in Havelsan, Ankara, Turkey in 1998-2006. He has been lecturing since then in the Department of Electronic and Communication Engineering of Cankaya University, Ankara, Turkey. His research interests include semiconductor characterization, laser beam propagation through atmosphere, LED applications, analog and digital electronic design with VHDL and FPGA.



Burcu YAKIŞIR received the B.Sc. degree in Electronic and Communication Engineering in Cankaya University, Ankara, Turkey in 2010. She is currently a graduate student in Department of Electronic and Communication Engineering of Cankaya University. She won the Ministry

of Science, Industry and Technology Project for young entrepreneurs, 2011. She has been working at her company BY Teknoloji since then. Her research interests are LED applications, designing electronic circuits with VHDL and FPGA.