

## PERFORMANCE OF TWO LEVEL TURBO CODED 4-ARY CPFSK SYSTEMS OVER AWGN AND FADING CHANNELS

**Niyazi ODABASIOGLU**

Istanbul University Engineering Faculty, Electrical and Electronics Dept.  
34320 Avcilar, Istanbul-Turkey

E-mail: niyazio@istanbul.edu.tr

### **ABSTRACT**

*This paper presents performance of two level turbo coded 4-ary continuous phase frequency shift keying. In this system,, to provide phase continuity of the transmitted signals, turbo encoder and continuous phase encoder (CPE) are serially concatenated at the second level, while first level consist of only a turbo encoder. Simulation results are drawn for proposed system over AWGN, Rician and Rayleigh channels for three iterations while frame sizes are chosen as 100 and 1024. High error performances are obtained for proposed system compared to Trellis Coded CPFSK system*

**Keywords:** Turbo coding, Multilevel coding, Continuous phase frequency shift keying

### **1. INTRODUCTION**

Turbo codes have been shown to provide excellent coding gains [1]. The performance of these new codes is close to the Shannon-limit with relatively simple component codes and large interleavers. Turbo codes are the most efficient codes for low-power applications such as deep space and satellite communications, as well as for interference limited applications such as third generation cellular and personal communication services.

In trellis based structures, to improve the bit error probability, many scientists not only study the channel parameters as in [2] but as in [3]-[6] they have also used multilevel coding as an

important band and power efficient technique, since it provides significant amount of coding gain and low coding complexity. Multilevel encoder is a combination of several error correction codes applied to subsets of some signal constellation. The multilevel coding scheme employs, at each signaling interval one or more output bits of each of several binary error-control encoders to construct the signal to be transmitted. An important parameter of a coded modulation scheme is the computational complexity of the decoder. Usually, a kind of suboptimal decoder, called the multistage decoder, is used for multilevel codes [5]-[7]. Nowadays, there are also many attempts to improve the performance of Multilevel Turbo-

based systems. In [8] the author discussed the impact of interleaver size on the performance of Multilevel Turbo based systems. Power and bandwidth efficiencies of Multilevel Turbo codes are also discussed in [9],[10]. In band-limited channels, such as deep space and satellite communications, Continuous Phase Modulation (CPM) has explicit advantages, since it has low spectral occupancy property [11],[12]. To improve error performance and bandwidth efficiency, we combined Multilevel Turbo Coding and Continuous Phase Modulation.

## 2. SYSTEM MODEL

### 2.1 Encoder Structure

Two level turbo coded 4-ary CPFSK system structure is consist of two parallel turbo encoder/decoder levels as in Figure 1. There is one binary Turbo encoder at first level of multilevel turbo encoder and Continuous Phase Encoder (CPE) is placed after the second level turbo encoder. Here, CPE is used to achieve the phase continuity of the transmitted signals and its state indicates the initial phase of the instant signal. Each turbo encoder is fed from one of the input bit streams, which are processed simultaneously. The outputs of these encoders can be punctured and thereafter only the second level output is passed through CPE. Then, these

outputs are mapped to 4-ary CPFSK signals according to the partitioning rule.

In partitioning,  $x_{k,l}$  is the output bit of the first level turbo encoder where signal set is divided into two subsets. If  $x_{k,l}=0$  then the first subset is chosen, if  $x_{k,l}=1$  then the second subset is chosen. The  $x_{k,2}$  bit is the output bit of the second level turbo encoder and divides the subsets into two same as previous levels. At the second level, to provide phase continuity CPE encoder is placed after last level turbo encoder. Therefore, at this level signal set is divided twice and hence the signal, which will be sent to channel, is selected. In each level, we consider a 1/3 Recursive Systematic Convolutional (RSC) encoder with memory size  $M=2$ . For each level, input bit streams are encoded by the turbo encoders. At turbo encoder outputs, the encoded bit streams to be mapped to 4-ary CPFSK signals are determined after a puncturing procedure. The first bit is taken from the first level turbo encoder output, the second bit is taken from second level encoder output and the other bits are obtained in similar way. Following this process, the bits at the outputs of the turbo encoders and continuous phase encoder are mapped to 4-ary CPFSK signals by using set partitioning technique, which is mentioned above. Set partitioning of 2LTC-CPFSK is shown in Figure 2.

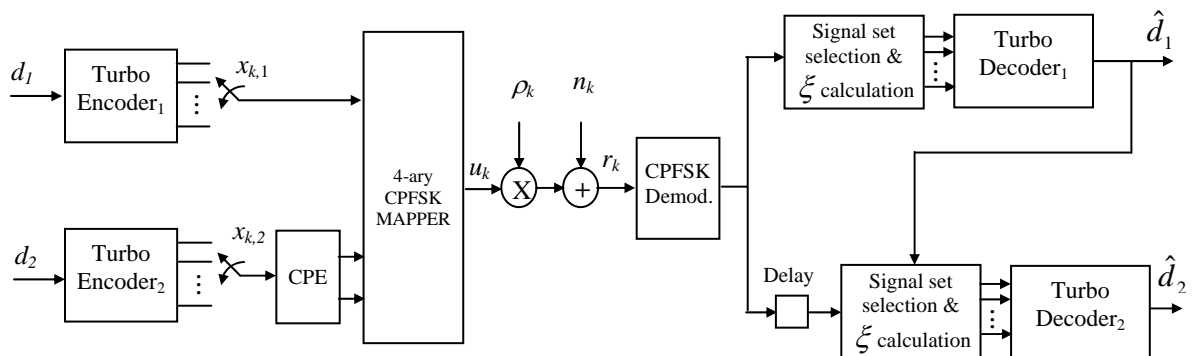

Figure 1. MLTC-CPFSK Block Diagram

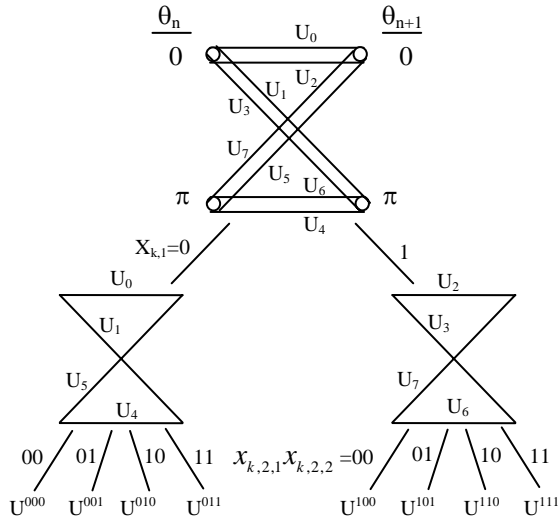

Figure 2. Set partitioning for 4-ary CPFSK

Here, if the output bit of the first level turbo encoder is  $x_{k,1}=0$ , then  $u_0^1$  set, if it is  $x_{k,1}=1$ , then  $u_1^1$  set is chosen. The first output bit  $\{x_{k,2,1}\}$  of the CPE determines whether  $u_1^2$  or  $u_0^2$  subsets to be chosen and the second output bit  $\{x_{k,2,2}\}$  of the CPE selects the signal, which will be transmitted using previous partitioning steps. In our case, RSC encoder has feedback polynomial  $g^{(0)}=7$  and feedforward polynomial  $g^{(1)}=5$ , and it has a generator matrix is,

$$G(D) = \begin{bmatrix} 1 & \frac{1+D+D^2}{1+D^2} \end{bmatrix} \quad (1)$$

## 2.2. Decoder Structure

The received signal can be shown as,

$$r_k = \rho_k u_k + n_k \quad (2)$$

where  $r_k$  is noisy received signal,  $u_k$  is transmitted MLTC-CPFSK signal,  $\rho_k$  is fading parameter and  $n_k$  is Gaussian noise at time  $k$ . The maximum a posteriori (MAP) algorithm calculates the a posteriori probability of each bit.

Let  $\bar{\gamma}^{st}(s_k \rightarrow s_{k+1})$  denote the natural logarithm of branch metric  $\gamma^{st}(s_k \rightarrow s_{k+1})$ , where  $s_k$  is encoder state at  $k$ th coding step and  $st$  is the decoding stage, then

$$\bar{\gamma}^{st}(s_k \rightarrow s_{k+1}) = \ln \gamma^{st}(s_k \rightarrow s_{k+1}) \quad (3)$$

$$\dots = \ln P[d_k] + \ln P[r_k | x_k]$$

where,

$$\ln P[d_k] = z_k d_k - \ln(1 + e^{z_k}) \quad (4)$$

$z_k$  is the a priori information which is obtained from the output of the other decoder. For every decoding stage of MLTC-CPFSK, zero and one probabilities  $\{P_{k,0}^{st}, P_{k,1}^{st}\}$  of the received signals are calculated at time  $k$  and decoding stage  $st \in \{1, 2, \dots, \log_2 M\}$  as below,

$$P_{k,0}^{st} = \sum_{j=0}^{(M/st)-1} \frac{1}{(v_k - u_{0,j}^{st})^2} \quad (5a)$$

$$P_{k,1}^{st} = \sum_{j=0}^{(M/st)-1} \frac{1}{(v_k - u_{1,j}^{st})^2} \quad (5b)$$

where,  $v_k$  is CPFSK demodulator output and  $\{u_{0,j}^{st}, u_{1,j}^{st}\}$  are signal sets which are obtained by the set selector using previous stage turbo decoder output  $\{\hat{d}_{st-1}\}$ . In MLTC-CPFSK scheme, each digit of binary correspondence of MCPFSK signals, matches to one stage from most significant to least significant while stage level  $st$  increases. Signal set is partitioned into the subsets due to the each binary digit matching stage depending on whether it is 0 or 1. After computing the one and zero probabilities as in Equation (5a) and (5b), received signal is mapped to  $\{-1, 1\}$  range using 0 and 1 probabilities of the received signal as,

$$\xi_k^{st,q} = 1 - \frac{2 \cdot P_{k,0}^{st}}{P_{k,0}^{st} + P_{k,1}^{st}} \quad (6)$$

These probability computations and mapping are executed in every stage of decoding process according to the signal set. In our decoder scheme in Figure 1, signal set selector operates using (5) and (6). In Thus, Equation (4) becomes

$$\bar{\gamma}^{st}(s_k \rightarrow s_{k+1}) = \ln P[d_k] - \frac{1}{2} \ln(\pi N_0 / E_s) \dots - \frac{E_s}{N_0} \sum_{q=0}^{n-1} [\xi_k^{st,q} - (2x^q - 1)]^2 \quad (7)$$

Now let  $\bar{\alpha}^{st}(s_k)$  be the natural logarithm of  $\bar{\alpha}^{st}(s_k)$ ,

$$\bar{\alpha}^{st}(s_k) = \ln \bar{\alpha}^{st}(s_k) \quad (8)$$

$$\begin{aligned} \bar{\beta}^{st}(s_k) &= \ln \beta^{st}(s_k) \\ &= \ln \left\{ \sum_{s_{k+1} \in B} \exp \left[ \bar{\beta}^{st}(s_{k+1}) + \bar{\gamma}^{st}(s_k \rightarrow s_{k+1}) \right] \right\} \end{aligned} \quad (9)$$

where  $B$  is the set of states  $s_{k+1}$  that are connected to state  $s_k$ , and we can calculate the Log Likelihood Ratio (LLR) by using

$$\Lambda_k^{st} = \ln \frac{\sum_{S_1} \exp \left[ \bar{\alpha}^{st}(s_k) + \bar{\gamma}^{st}(s_k \rightarrow s_{k+1}) + \bar{\beta}^{st}(s_{k+1}) \right]}{\sum_{S_0} \exp \left[ \bar{\alpha}^{st}(s_k) + \bar{\gamma}^{st}(s_k \rightarrow s_{k+1}) + \bar{\beta}^{st}(s_{k+1}) \right]} \quad (10)$$

where  $S_1 = \{s_k \rightarrow s_{k+1} : d_k = 1\}$  is the set of all state transitions associated with a message bit of 1, and  $S_0 = \{s_k \rightarrow s_{k+1} : d_k = 0\}$  is the set of all state transitions associated with a message bit of 0. At the last iteration we make the hard decision by using the second decoder output  $\Lambda(st, 2)$ ,

$$\hat{d}_k = \begin{cases} 1 & \text{if } \Lambda(st, 2) \geq 0 \\ 0 & \text{if } \Lambda(st, 2) < 0 \end{cases} \quad (11)$$

### 3. SIMULATION RESULTS

The Bit Error Ratio (BER) versus Signal to Noise Ratio (SNR) curves of two level turbo coded 4CPFSK system are obtained for AWGN, Rician (for Rician channel parameter  $K=10$  dB) and Rayleigh channels. The results are shown in Figure 3,4. Here, frame sizes are chosen 100 and 1024. To compare our scheme's performance, we selected a well-known best code from literature, which is presented in [13] by Naraghi-Pour. In our study, these reference codes are called Ref-1. Ref-1 is binary trellis coded 4-ary CPFSK scheme with  $R_s=2/3$  coding rate. Our example, 2LTC-CPFSK system, is very suitable for comparison with Ref-1, since they both have 4-ary CPFSK with  $R_s=2/3$ . Our proposed system have better error performance than Ref-1 in all channels and SNR values. As an example, the proposed systems have coding gain between 3.1-5.7 dB for the same channels with a bit error rate of  $10^{-4}$  when compared to reference system. For the frame size 1024, at a bit error probability of  $10^{-4}$ , 2LTC-CPFSK system provides 4.2, 4.4, 5.7 dB coding gains over Ref-1 for AWGN, Rician and Rayleigh channels respectively.

Furthermore, there is only approximately 0.5 dB gain by increasing frame size from 100 to 1024. Thus, in our model, even if small frame sizes are chosen, sufficient bit error probabilities are obtained.

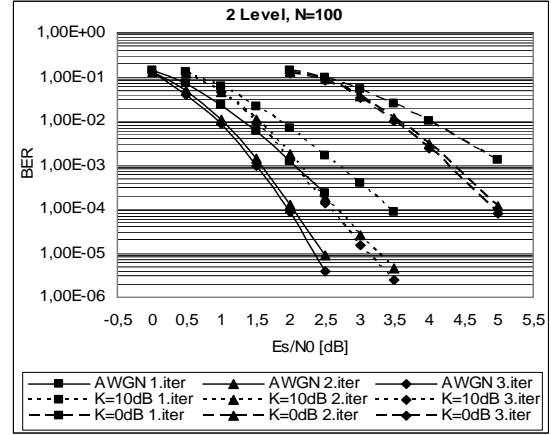

Figure 3. Performance curves of 2LTC-4ary CPFSK System for  $N=100$

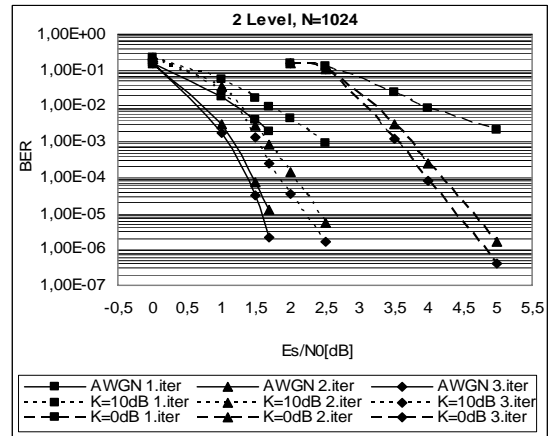

Figure 4. Performance curves of 2LTC-4ary CPFSK System for  $N=1024$

### 4. CONCLUSIONS

In this paper, error performance of two level turbo coded 4-ary CPFSK system is studied. Binary turbo codes are used instead of classical convolutional codes at each coding level in Imai-Hirakawa type multilevel coding scheme. Besides, multilevel turbo codes and CPFSK modulation are combined at one structure. Beside, multilevel turbo coded CPFSK systems, which has better error performance than the

corresponding reference system, is obtained. Also, 2LTC-CPFSK system's error performance curves are obtained via computer simulation over AWGN and fading channels. In our scheme, decoding delay can be minimized, since sufficient bit error rate is reached in a few number of iterations. In this case, we have shown that, 2LTC-4CPFSK system provides considerable coding gain up to 5.7 dB. Furthermore, since CPFSK is selected, proposed system has also bandwidth efficiency.

## REFERENCES

- [1] C. Berrou, A Glavieux, and P. Thitimajshima, "Near Shannon-limit error correcting coding and decoding: Turbo codes", in Proc., *IEEE Int. Conf. on Commun.*, (Geneva, Switzerland), pp. 1064-1070, May 1993.
- [2] O. Osman, O.N. Ucan, "Blind Equalization of Turbo Trellis Coded Partial Response Continuous Phase Modulation Signaling Over Narrow-Band Rician Fading Channels", *IEEE Trans. on Wireless Communications*. Vol.4, pp..397-403, March 2005.
- [3] H.Imai and S.Hirakawa, "A new multilevel coding method using error-correcting codes", *IEEE Trans. On Inform. Theory*, Vol.IT-23, pp.371-377, May 1977.
- [4] K.Yamaguchi and H.Imai, "Highly reliable multilevel channel coding system using binary convolutional codes", *Electron. Letter.*,Vol.23, pp.939-941, Aug.1987.
- [5] G.J. Pottie and D.P.Taylor, "Multilevel codes based on partitioning", *IEEE Trans. Inform. Theory*, Vol.35, pp.87-98, Jan. 1989.
- [6] A.R. Calderbank, "Multilevel codes and multistage decoding", *IEEE Trans. on Commun.*, Vol.37, pp.222-229, Mar. 1989.
- [7] G.D. Forney, "A bounded-distance decoding algorithm for the Leech lattice, with generalization," *IEEE Trans. on Inform. Theory*, Vol. 35, July 1989.
- [8] H. Herzberg, "Multilevel Turbo Coding With Short Interleavers", *IEEE Journal on Selected Areas In Commun.*, vol.16, pp.303-309, February 1998.
- [9] U. Waschman, Robert F.H. Fischer, J.B. Huber, "Multilevel codes: theoretical concepts and practical design rules", *IEEE Trans. on Inform. Theory*, Vol.45, pp.1361-1391, July 1999.
- [10] O. Osman, O.N. Ucan, N. Odabasioglu, "Performance of Multi Level-Turbo Codes with Group Partitioning over Satellite Channels" to be appeared in *IEE Proceeding Communication*.
- [11] B.E. Rimoldi, "A decomposition approach to CPM," *IEEE Trans. on Inform. Theory*, Vol. 34, pp. 260-270, Mar. 1988.
- [12] B.E. Rimoldi, "Design of coded CPFSK modulation systems for band-width and energy efficiency," *IEEE Trans.on Commun.*, Vol. 37, pp. 897-905, Sept. 1989.
- [13] M. Naraghi-Pour, "Trellis codes for 4-ary continuous phase frequency shift keying," *IEEE Trans. on Commun.*, Vol. 41, pp. 1582-1587, Nov. 1993.

**Niyazi Odabaşıoğlu** was born in Konya, Turkey in 1978. He received the B.Sc. degree from the University of Istanbul Department of Electrical and Electronics Engineering in 1999, the M.Sc. degree from the University of Istanbul, Istanbul, Turkey in 2002. Since 1999 he has been working as a research assistant in Istanbul University Engineering Faculty, Department of Electrical and Electronics Engineering where he continues to work on his Ph.D. dissertation. His current research interests are channel coding, digital modulation schemes and image transmission.